

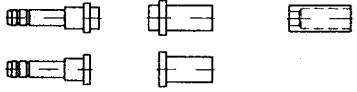









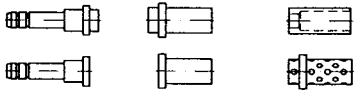

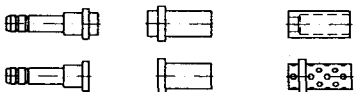

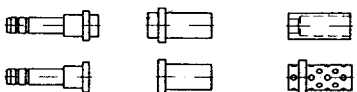

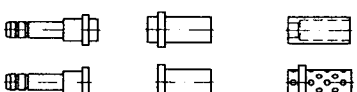

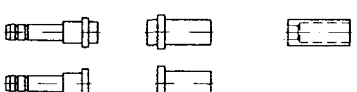
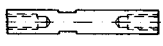

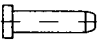

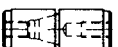







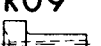













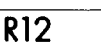

<b>R01 - R05</b> Führungssystem $\varnothing 14$ 	1.1	<b>R13</b> Angußhaltebuchse 2.3 	<b>R621</b> Isolierplatte mit Bohrung 4.3 
<b>R01 - R06</b> Führungssystem $\varnothing 20$ 	1.1	<b>R14</b> Kugelführung 2.3 	<b>R40</b> O-Ring Viton 5.1 
<b>R01 - R06</b> Führungssystem $\varnothing 26$ 	1.2	<b>R15</b> Führungsbolzen für Kugelführung 2.4 	<b>R46</b> Schlauchtülle 5.2 
<b>R01 - R06</b> Führungssystem $\varnothing 30$ 	1.2	<b>R16</b> Führungsbolzen für Kugelführung 2.4 	<b>R461</b> Schlauchtülle abgewinkelt 5.2 
<b>R01 - R06</b> Führungssystem $\varnothing 42$ 	1.3	<b>R17</b> Führungshülse Zentrierhülse 2.4 	<b>R462</b> Verlängerungstülle 5.2 
<b>R01 - R06</b> Führungssystem $\varnothing 54$ 	1.3	<b>AL</b> Ausstoßbolzen 2.5 	<b>R48</b> Verschlussschraube 5.2 
<b>R07</b> Führungsbolzen Schrägbolzen 2.1 		<b>ALS</b> Haltescheibe zur Abstützung der Feder 2.5 	<b>R49</b> Schnellkupplung ohne Ventil 5.3 
<b>R08</b> Zentriereinheit 2.1 		<b>ZR</b> Zentrierflansch ohne Ausdrehung 2.5 	<b>R491</b> Schnellkupplung ohne Ventil 5.3 
<b>R081</b> Distanzscheibe für Zentriereinheit 2.1 		<b>ZRA</b> Zentrierflansch mit Ausdrehung 2.5 	<b>R492</b> Schnellkupplung ohne Ventil 5.3 
<b>R082</b> Haltescheibe für Zentriereinheit 2.1 		<b>R20</b> Auswerferstift nitriert 3.1 	<b>R50</b> Schnellverschlußkupplung 5.3 
<b>R09</b> Angußbuchse 1°/1.5° 2.2 		<b>R201</b> Auswerferstift gehärtet 3.1 	<b>R501</b> Schnellverschlußkupplung 5.4 
<b>R10</b> Distanzbolzen 2.2 		<b>R21</b> Auswerferstift gehärtet 3.2 	<b>R502</b> Schnellverschlußkupplung 5.4 
<b>R11</b> Auflagebolzen für Auswerferplatten 2.2 		<b>R22</b> Auswerferstift nitriert 3.3 	<b>R51</b> Anschlußnippel passend zu R49../R50.. 5.4 
<b>R111</b> Auflagerscheibe für Auswerferplatten 2.2 		<b>R221</b> Auswerferstift gehärtet 3.3 	<b>R511</b> Anschlußnippel passend zu R49../R50.. 5.4 
<b>R112</b> Auflagebolzen für Auswerferplatten 2.2 		<b>R24</b> Auswerferhülse nitriert 3.4 	<b>R512</b> Verlängerungsnippel passend zu R49../R50.. 5.5 
<b>R12</b> Federndes Druckstück 2.3 		<b>R241</b> Auswerferhülse gehärtet 3.4 	<b>R52</b> Verschlußnippel passend zu R49../R50.. 5.5 
		<b>R25</b> Flachauswerfer nitriert 3.5 	<b>R53</b> Dichtband Teflon 5.5 
		<b>R251</b> Flachauswerfer gehärtet 3.5 	
		<b>R35</b> Zylinderschraube DIN 912 4.1 	
		<b>R37</b> Ringschraube 4.1 	
		<b>R56</b> Tellerfeder 4.2 	
		<b>R62</b> Isolierplatte ohne Bohrung 4.3 	

## System-Ø 14

R01/S2x10/9xL

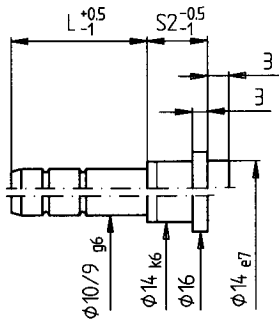

L	20	25	30	35	45	50	55	60	65	70	75	85	90	95
S2														
12														
17														
22														
27														
36														
46														
56														

R02/S2x10/9xL

R03/10/9x

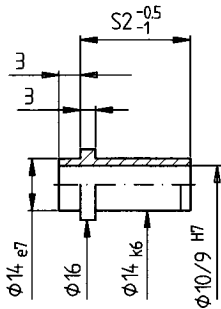

S2
12
17
22
27
36
46
56
66

R04/10/9x

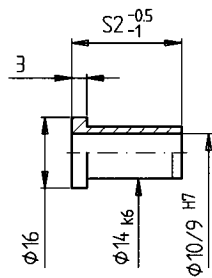

S2
9
12
17
22
27
36
46
56
66

R05/10/9x

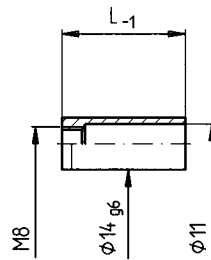

L
20
30
40
50
60
70
80
100

Stand 05/94

## System-Ø 20

R01/S2x15/14xL

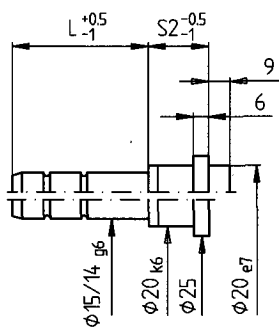

L	30	35	45	50	55	65	70	75	85	90	95	105	110	125	135	145	150	155	165	
S2																				
22																				
27																				
36																				
46																				
56																				
66																				
76																				
86																				
96																				
116																				

R02/S2x15/14xL

R03/15/14x

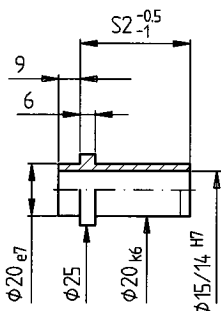

S2
22
27
36
46
56
66
76
86
96
116

R04/15/14x

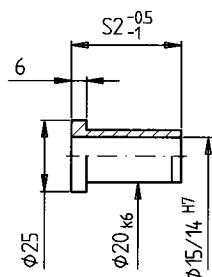

S2
22
27
36
46
56
66
76
86
96

R05/15/14x

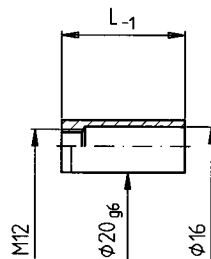

L
30
40
60
80
100
120
140
160

R06/15/14x

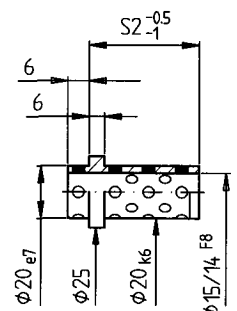

S2
22
27
36

## System - $\varnothing$ 26

R01/S2x20/18xL

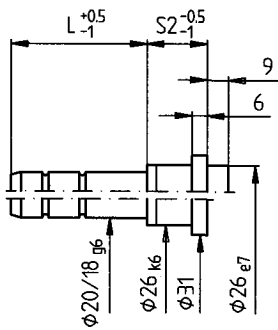

L \ S2	35	45	55	65	75	85	95	105	115	125	135	145	155	165	225	245	255
22	<input type="checkbox"/>	<input type="checkbox"/>		<input type="checkbox"/>		<input type="checkbox"/>			<input type="checkbox"/>								
27	<input type="checkbox"/>	<input type="checkbox"/>		<input type="checkbox"/>		<input type="checkbox"/>		<input type="checkbox"/>		<input type="checkbox"/>				<input type="checkbox"/>	<input type="checkbox"/>	<input type="checkbox"/>	
36	<input type="checkbox"/>		<input type="checkbox"/>		<input type="checkbox"/>		<input type="checkbox"/>		<input type="checkbox"/>		<input type="checkbox"/>			<input type="checkbox"/>	<input type="checkbox"/>		<input type="checkbox"/>
46	<input type="checkbox"/>	<input type="checkbox"/>		<input type="checkbox"/>		<input type="checkbox"/>		<input type="checkbox"/>			<input type="checkbox"/>			<input type="checkbox"/>		<input type="checkbox"/>	
56	<input type="checkbox"/>		<input type="checkbox"/>		<input type="checkbox"/>		<input type="checkbox"/>					<input type="checkbox"/>					
66	<input type="checkbox"/>		<input type="checkbox"/>		<input type="checkbox"/>		<input type="checkbox"/>				<input type="checkbox"/>						
76			<input type="checkbox"/>		<input type="checkbox"/>		<input type="checkbox"/>				<input type="checkbox"/>						
86			<input type="checkbox"/>		<input type="checkbox"/>		<input type="checkbox"/>										
96			<input type="checkbox"/>				<input type="checkbox"/>										
116					<input type="checkbox"/>				<input type="checkbox"/>								
136										<input type="checkbox"/>							

R02/S2x20/18xL

R03/20/18x

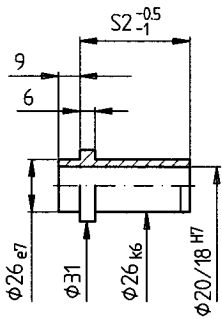

S2

22
27
36
46
56
66
76
86
96
116
136

R04/20/18x

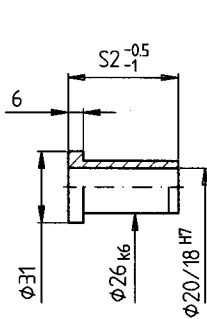

S2

22
27
36
46
56
66
76
86
96
116

R05/20/18x

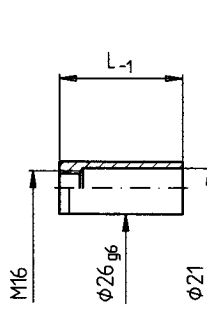

L

30
40
60
80
100
120
140
160
180

R06/20/18x

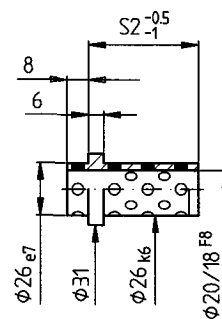

S2

22
27
36

R01/S2x24/22xL

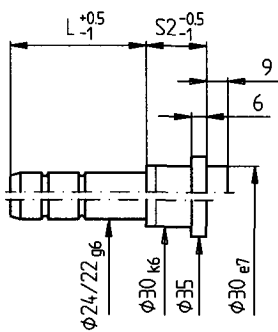

## System - $\varnothing$ 30

L \ S2	35	45	55	65	75	85	95	105	115	125	130	135	145	155	165	205	245	285
22	<input type="checkbox"/>		<input type="checkbox"/>		<input type="checkbox"/>			<input type="checkbox"/>			<input type="checkbox"/>							
27	<input type="checkbox"/>	<input type="checkbox"/>		<input type="checkbox"/>		<input type="checkbox"/>		<input type="checkbox"/>		<input type="checkbox"/>					<input type="checkbox"/>	<input type="checkbox"/>	<input type="checkbox"/>	<input type="checkbox"/>
36	<input type="checkbox"/>		<input type="checkbox"/>		<input type="checkbox"/>		<input type="checkbox"/>		<input type="checkbox"/>		<input type="checkbox"/>				<input type="checkbox"/>	<input type="checkbox"/>	<input type="checkbox"/>	<input type="checkbox"/>
46	<input type="checkbox"/>	<input type="checkbox"/>		<input type="checkbox"/>		<input type="checkbox"/>		<input type="checkbox"/>		<input type="checkbox"/>					<input type="checkbox"/>	<input type="checkbox"/>		<input type="checkbox"/>
56	<input type="checkbox"/>		<input type="checkbox"/>		<input type="checkbox"/>		<input type="checkbox"/>		<input type="checkbox"/>						<input type="checkbox"/>	<input type="checkbox"/>		
66	<input type="checkbox"/>		<input type="checkbox"/>		<input type="checkbox"/>		<input type="checkbox"/>		<input type="checkbox"/>					<input type="checkbox"/>				
76			<input type="checkbox"/>		<input type="checkbox"/>		<input type="checkbox"/>		<input type="checkbox"/>				<input type="checkbox"/>					
86			<input type="checkbox"/>		<input type="checkbox"/>		<input type="checkbox"/>		<input type="checkbox"/>				<input type="checkbox"/>					
96			<input type="checkbox"/>		<input type="checkbox"/>		<input type="checkbox"/>		<input type="checkbox"/>									
116					<input type="checkbox"/>				<input type="checkbox"/>									
136					<input type="checkbox"/>					<input type="checkbox"/>								
156														<input type="checkbox"/>				

R02/S2x24/22xL

R03/24/22x

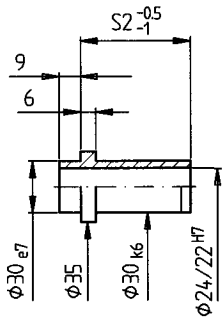

S2

22
27
36
46
56
66
76
86
96
116
136
156

R04/24/22x

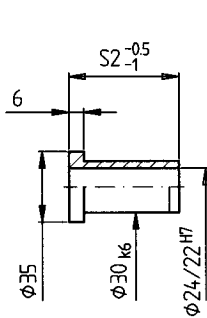

S2

22
27
36
46
56
66
76
86
96
116
136

R05/24/22x

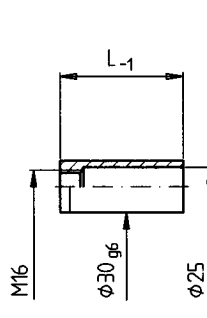

L

40
60
80
100
120
140
160
180
200
240

R06/24/22x

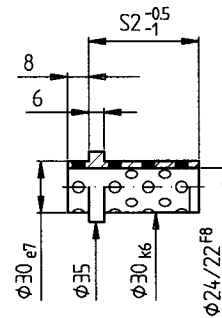

S2

27
36
46
56

## System- $\varnothing$ 42

### R01/S2x32/30xL

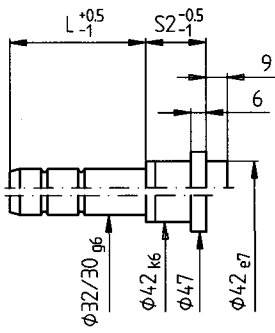

L	45	55	65	75	85	95	105	115	125	135	155	165	175	185	195	205	225	245	285	295	
<b>S2</b>																					
27	<input type="checkbox"/>		<input type="checkbox"/>				<input type="checkbox"/>					<input type="checkbox"/>		<input type="checkbox"/>					<input type="checkbox"/>	<input type="checkbox"/>	
36		<input type="checkbox"/>		<input type="checkbox"/>		<input type="checkbox"/>		<input type="checkbox"/>				<input type="checkbox"/>							<input type="checkbox"/>	<input type="checkbox"/>	
46	<input type="checkbox"/>		<input type="checkbox"/>			<input type="checkbox"/>	<input type="checkbox"/>		<input type="checkbox"/>			<input type="checkbox"/>							<input type="checkbox"/>	<input type="checkbox"/>	
56		<input type="checkbox"/>		<input type="checkbox"/>		<input type="checkbox"/>		<input type="checkbox"/>		<input type="checkbox"/>			<input type="checkbox"/>						<input type="checkbox"/>	<input type="checkbox"/>	<input type="checkbox"/>
66		<input type="checkbox"/>		<input type="checkbox"/>		<input type="checkbox"/>		<input type="checkbox"/>					<input type="checkbox"/>						<input type="checkbox"/>	<input type="checkbox"/>	
76		<input type="checkbox"/>		<input type="checkbox"/>		<input type="checkbox"/>		<input type="checkbox"/>				<input type="checkbox"/>							<input type="checkbox"/>	<input type="checkbox"/>	
86		<input type="checkbox"/>		<input type="checkbox"/>		<input type="checkbox"/>		<input type="checkbox"/>				<input type="checkbox"/>							<input type="checkbox"/>	<input type="checkbox"/>	
96		<input type="checkbox"/>		<input type="checkbox"/>		<input type="checkbox"/>		<input type="checkbox"/>				<input type="checkbox"/>							<input type="checkbox"/>	<input type="checkbox"/>	
116				<input type="checkbox"/>				<input type="checkbox"/>				<input type="checkbox"/>							<input type="checkbox"/>	<input type="checkbox"/>	
136								<input type="checkbox"/>				<input type="checkbox"/>							<input type="checkbox"/>	<input type="checkbox"/>	
156												<input type="checkbox"/>							<input type="checkbox"/>	<input type="checkbox"/>	
196																			<input type="checkbox"/>	<input type="checkbox"/>	

### R02/S2x32/30xL

### R03/32/30x

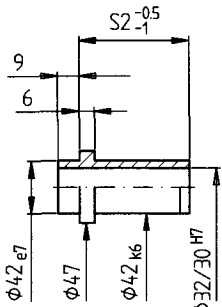

S2
27
36
46
56
66
76
86
96
116
136
156
196

### R04/32/30x

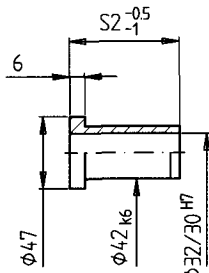

S2
27
36
46
56
66
76
86
96
116
136
156

### R05/32/30x

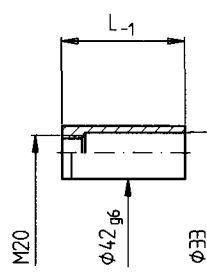

L
40
60
80
100
120
140
160
180
200
220
260
300

### R06/32/30x

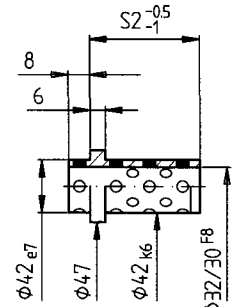

S2
36
46
56
76

Stand 05/94

### R01/S2x42/40xL

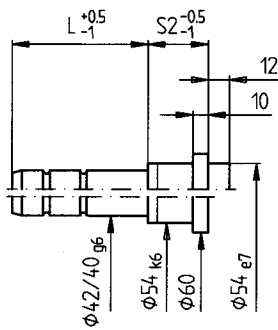

L	75	95	115	135	155	165	175	195	215	235	245
<b>S2</b>											
46		<input type="checkbox"/>				<input type="checkbox"/>					
56	<input type="checkbox"/>		<input type="checkbox"/>		<input type="checkbox"/>			<input type="checkbox"/>			
66	<input type="checkbox"/>		<input type="checkbox"/>	<input type="checkbox"/>				<input type="checkbox"/>			
76	<input type="checkbox"/>		<input type="checkbox"/>				<input type="checkbox"/>				
86	<input type="checkbox"/>		<input type="checkbox"/>	<input type="checkbox"/>							
96	<input type="checkbox"/>		<input type="checkbox"/>		<input type="checkbox"/>						
116		<input type="checkbox"/>		<input type="checkbox"/>				<input type="checkbox"/>			
136		<input type="checkbox"/>		<input type="checkbox"/>					<input type="checkbox"/>		
156			<input type="checkbox"/>		<input type="checkbox"/>				<input type="checkbox"/>		
196				<input type="checkbox"/>				<input type="checkbox"/>		<input type="checkbox"/>	
246										<input type="checkbox"/>	

### R02/S2x42/40xL

### R03/42/40x

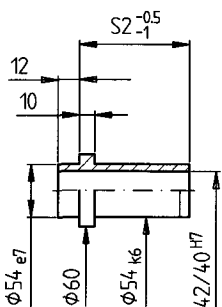

S2
46
56
66
76
86
96
116
136
156
196
246

### R04/42/40x

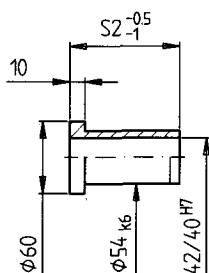

S2
46
56
66
76
86
96
116
136
156
196
246

### R05/42/40x

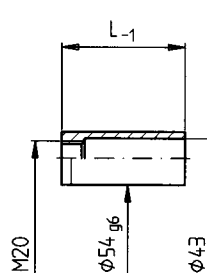

L
60
80
120
160
200
240
280



## R09/d2xL/d1/R

R=0/15.5/40

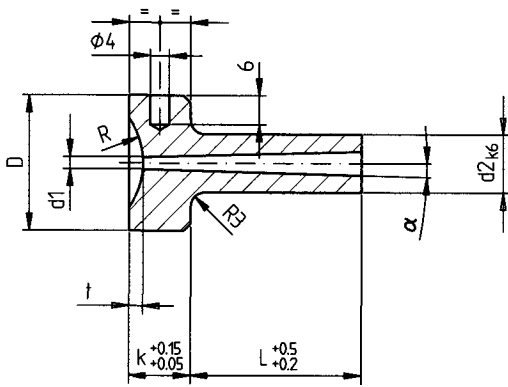

$\alpha = 1^\circ$

d2	d1	D	k	t	L	22	27	36	46	56	76	96	116
12	2.5	28	13	15		<input type="checkbox"/>	<input type="checkbox"/>	<input type="checkbox"/>	<input type="checkbox"/>				
	3.5					<input type="checkbox"/>	<input type="checkbox"/>	<input type="checkbox"/>	<input type="checkbox"/>				
18	3	38	18	3		<input type="checkbox"/>	<input type="checkbox"/>	<input type="checkbox"/>	<input type="checkbox"/>	<input type="checkbox"/>	<input type="checkbox"/>	<input type="checkbox"/>	<input type="checkbox"/>
	4					<input type="checkbox"/>	<input type="checkbox"/>	<input type="checkbox"/>	<input type="checkbox"/>	<input type="checkbox"/>	<input type="checkbox"/>	<input type="checkbox"/>	<input type="checkbox"/>

$\alpha = 15^\circ$

d2	d1	D	k	t	L	22	27	36	46	56	76	96	116
18	3.5	38	18	3		<input type="checkbox"/>	<input type="checkbox"/>	<input type="checkbox"/>	<input type="checkbox"/>				
	4.5					<input type="checkbox"/>	<input type="checkbox"/>	<input type="checkbox"/>	<input type="checkbox"/>				
24	4.5	48	23	3				<input type="checkbox"/>	<input type="checkbox"/>	<input type="checkbox"/>			
	6.5							<input type="checkbox"/>	<input type="checkbox"/>	<input type="checkbox"/>			

1.2826 / 55 ± 2 HRC

## R10/DxL

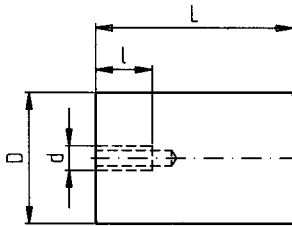

D	d	L	36	46	56	66	76	86	96	116	136	156	166	186
30	M8	15	<input type="checkbox"/>	<input type="checkbox"/>	<input type="checkbox"/>	<input type="checkbox"/>	<input type="checkbox"/>	<input type="checkbox"/>	<input type="checkbox"/>					
40	M8	15		<input type="checkbox"/>	<input type="checkbox"/>	<input type="checkbox"/>	<input type="checkbox"/>	<input type="checkbox"/>	<input type="checkbox"/>	<input type="checkbox"/>				
50	M10	18			<input type="checkbox"/>	<input type="checkbox"/>	<input type="checkbox"/>	<input type="checkbox"/>	<input type="checkbox"/>	<input type="checkbox"/>	<input type="checkbox"/>	<input type="checkbox"/>	<input type="checkbox"/>	<input type="checkbox"/>
60	M10	18			<input type="checkbox"/>	<input type="checkbox"/>	<input type="checkbox"/>	<input type="checkbox"/>	<input type="checkbox"/>	<input type="checkbox"/>	<input type="checkbox"/>	<input type="checkbox"/>	<input type="checkbox"/>	<input type="checkbox"/>
80	M12	20				<input type="checkbox"/>	<input type="checkbox"/>	<input type="checkbox"/>	<input type="checkbox"/>	<input type="checkbox"/>	<input type="checkbox"/>	<input type="checkbox"/>	<input type="checkbox"/>	<input type="checkbox"/>

1.1730

## R11/DxH

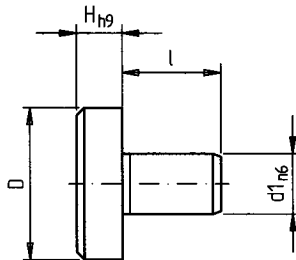

D	d1	l	H	5	8	13	20	32
6	4	6		<input type="checkbox"/>				
10	6	8			<input type="checkbox"/>			
16	8	10				<input type="checkbox"/>		
25	12	14					<input type="checkbox"/>	
40	20	20						<input type="checkbox"/>

WSt., geh.

## R111/D

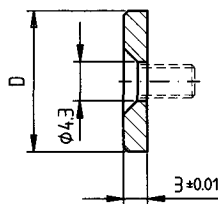

**D**  
18  
28

1.0711

## R112/D

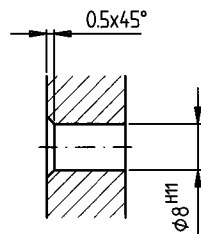
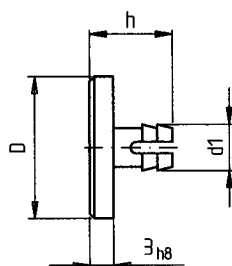

**D** | **d1** | **h**  
16 | 8.2 | 11  
25

1.8159 / 46 ± 2 HRC

Stand 05.94

D	l	d2	d3	s	F1 [N]	F2 [N]
M4	9	2.5	2	0.8	8	16
M5	12	3	2.5	0.9	7	13
M6	14	3.5	3	1	11	16
M8	16	5	4.2	1.5	21	35
M10	19	6	5.5	2	24	44
M12	22	8	7	2.5	25	47
M16	24	10	9	3.5	65	105

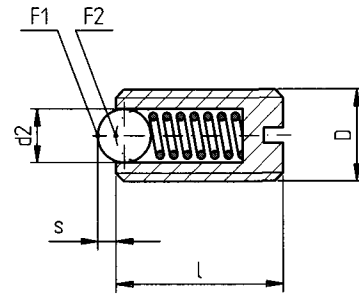
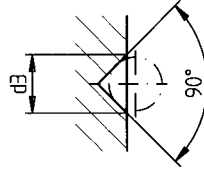

F[N] x 0.102 = F[kp]

10711

## R13/DxL

D	d1	d2	d3	l1	L								
					22	27	36	46	56	76	96		
12	4	4.5	16	18	7	□	□	□	□				
18	6	6.5	22	-	28	□	□						
24	8	8.5	28	28	9.5			□	□	□	□	□	□

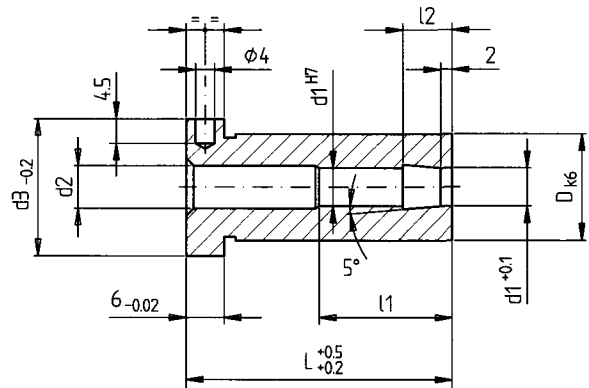

12826 / 55 ± 2 HRC

## R14/DxL

D	L	H <sub>max</sub>	d1	d2	l1	l2	f	s
12	40	50	22	26	24	2.1	6	18
	56	82						
18	45	44	30	35	34	3	11	23
	56	66						
	71	96						
30	56	32	46	52	54	4.8	21	33
	75	70						
	95	110						

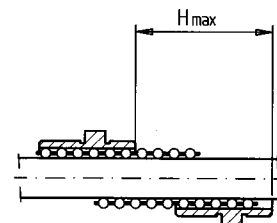
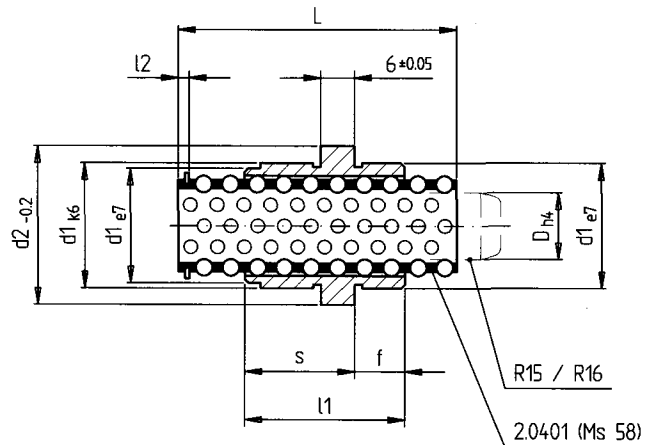

Stand: 05.94

1.3505

## R15/DxL

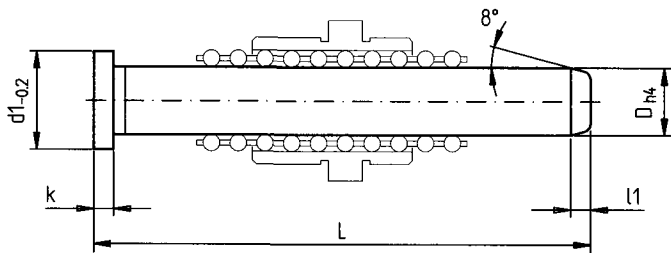

D	d1	k	l1	L								
				80	100	120	140	160	200	240		
12	16	4	4	<input type="checkbox"/>	<input type="checkbox"/>	<input type="checkbox"/>						
18	22	6	7			<input type="checkbox"/>	<input type="checkbox"/>	<input type="checkbox"/>				
30	36								<input type="checkbox"/>	<input type="checkbox"/>	<input type="checkbox"/>	

18159 / 62 ± 2 HRC

## R16/DxL

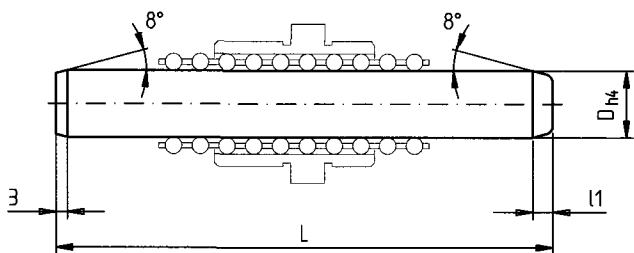

D	l1	L			
		100	125	160	240
12	4	<input type="checkbox"/>	<input type="checkbox"/>		
18	7		<input type="checkbox"/>	<input type="checkbox"/>	
30				<input type="checkbox"/>	<input type="checkbox"/>

18159 / 62 ± 2 HRC

## R17/DxL

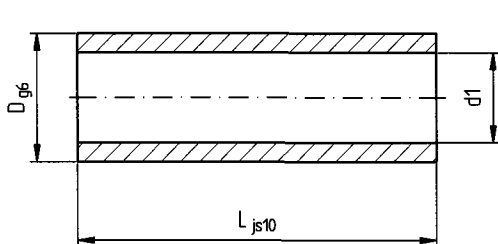

D	d1	L																	
		20	30	40	50	60	70	80	100	120	140	160	180	200	220	240	260	300	
10	6.2	<input type="checkbox"/>																	
14	8.3		<input type="checkbox"/>																
18	10.4			<input type="checkbox"/>															
24	12.5				<input type="checkbox"/>														
30	16.5					<input type="checkbox"/>													

1.0715 / 620 HV 30

Stand 05/94

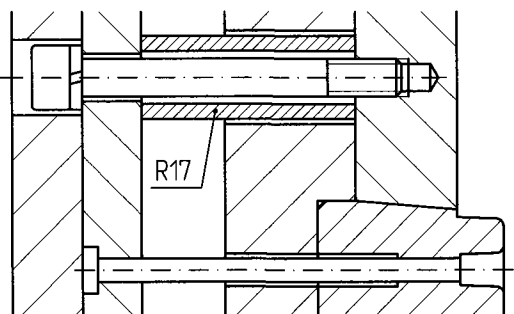
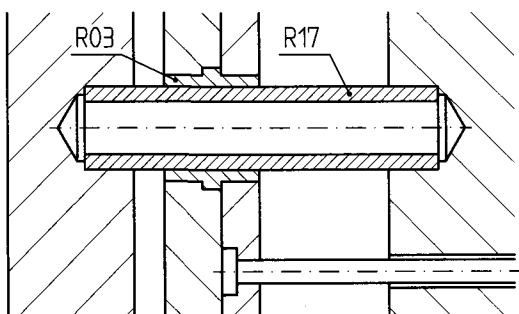
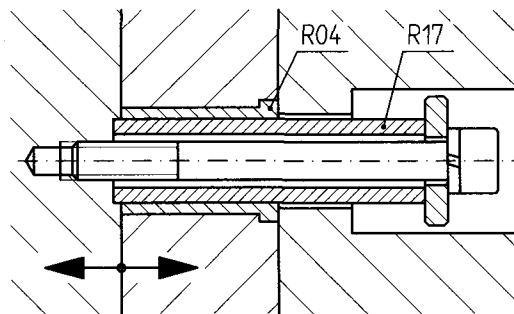
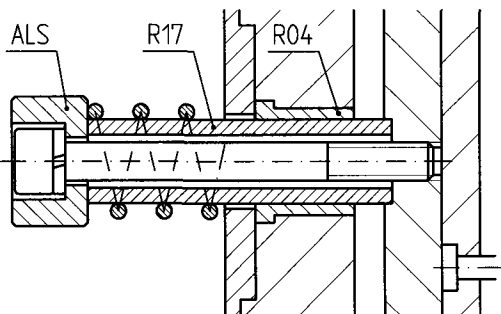

## AL/DxL

D	d	L		60	70	80	100	120	140	160	180	200	220	240	260	300
		l1	l2													
10	M6	9	16	<input type="checkbox"/>	<input type="checkbox"/>	<input type="checkbox"/>	<input type="checkbox"/>	<input type="checkbox"/>	<input type="checkbox"/>							
14	M8	11	16	<input type="checkbox"/>	<input type="checkbox"/>	<input type="checkbox"/>	<input type="checkbox"/>	<input type="checkbox"/>	<input type="checkbox"/>	<input type="checkbox"/>	<input type="checkbox"/>					
18	M10	12	20				<input type="checkbox"/>	<input type="checkbox"/>	<input type="checkbox"/>	<input type="checkbox"/>	<input type="checkbox"/>	<input type="checkbox"/>				
24	M12	14	25				<input type="checkbox"/>	<input type="checkbox"/>	<input type="checkbox"/>	<input type="checkbox"/>	<input type="checkbox"/>	<input type="checkbox"/>	<input type="checkbox"/>	<input type="checkbox"/>		
30	M16	16	30								<input type="checkbox"/>		<input type="checkbox"/>	<input type="checkbox"/>	<input type="checkbox"/>	<input type="checkbox"/>

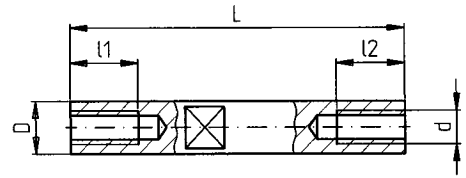

10401 / 720 HV 30

## ALS/DxH

D	H	d1	d2	t
15	10	11	6.6	8.4
22	14	14.5	9	11
36	20	17.5	11	13.5
46	25	20	14	15.5
56	32	26	18	21

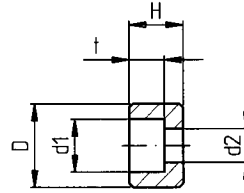

1.1730

## ZR/DxH

H	s	D							
		90	100	110	125	160	175	200	250
8	0	<input type="checkbox"/>	<input type="checkbox"/>	<input type="checkbox"/>	<input type="checkbox"/>				
12		<input type="checkbox"/>	<input type="checkbox"/>	<input type="checkbox"/>	<input type="checkbox"/>	<input type="checkbox"/>	<input type="checkbox"/>	<input type="checkbox"/>	<input type="checkbox"/>
11	3	<input type="checkbox"/>	<input type="checkbox"/>	<input type="checkbox"/>	<input type="checkbox"/>				
13	5	<input type="checkbox"/>	<input type="checkbox"/>	<input type="checkbox"/>	<input type="checkbox"/>	<input type="checkbox"/>	<input type="checkbox"/>		
15	7	<input type="checkbox"/>	<input type="checkbox"/>	<input type="checkbox"/>	<input type="checkbox"/>	<input type="checkbox"/>	<input type="checkbox"/>	<input type="checkbox"/>	
16.5	8.5	<input type="checkbox"/>	<input type="checkbox"/>	<input type="checkbox"/>	<input type="checkbox"/>	<input type="checkbox"/>	<input type="checkbox"/>		

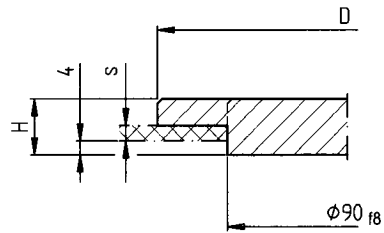

1.1730

## ZRA/DxH

H	s	D							
		90	100	110	125	160	175	200	250
8	0	<input type="checkbox"/>	<input type="checkbox"/>	<input type="checkbox"/>	<input type="checkbox"/>				
12		<input type="checkbox"/>	<input type="checkbox"/>	<input type="checkbox"/>	<input type="checkbox"/>	<input type="checkbox"/>	<input type="checkbox"/>	<input type="checkbox"/>	<input type="checkbox"/>
11	3	<input type="checkbox"/>	<input type="checkbox"/>	<input type="checkbox"/>	<input type="checkbox"/>				
13	5	<input type="checkbox"/>	<input type="checkbox"/>	<input type="checkbox"/>	<input type="checkbox"/>	<input type="checkbox"/>	<input type="checkbox"/>		
15	7	<input type="checkbox"/>	<input type="checkbox"/>	<input type="checkbox"/>	<input type="checkbox"/>	<input type="checkbox"/>	<input type="checkbox"/>	<input type="checkbox"/>	
16.5	8.5	<input type="checkbox"/>	<input type="checkbox"/>	<input type="checkbox"/>	<input type="checkbox"/>	<input type="checkbox"/>	<input type="checkbox"/>		

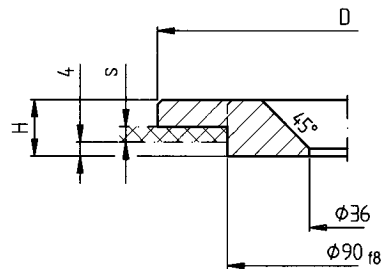

1.1730

Stand 05/94

## R20/DxL

gasnitriert  
DIN 1530-A

D	d1	k	L		100	125	160	200	250	315	400	500	630	800	1000
			r	r											
15	3	15	0.2		<input type="checkbox"/>	<input type="checkbox"/>	<input type="checkbox"/>	<input type="checkbox"/>							
2	4	2			<input type="checkbox"/>	<input type="checkbox"/>	<input type="checkbox"/>	<input type="checkbox"/>	<input type="checkbox"/>	<input type="checkbox"/>					
2.2			0.3		<input type="checkbox"/>	<input type="checkbox"/>	<input type="checkbox"/>	<input type="checkbox"/>	<input type="checkbox"/>						
2.5	5				<input type="checkbox"/>	<input type="checkbox"/>	<input type="checkbox"/>	<input type="checkbox"/>	<input type="checkbox"/>	<input type="checkbox"/>	<input type="checkbox"/>				
2.7			0.3		<input type="checkbox"/>	<input type="checkbox"/>	<input type="checkbox"/>	<input type="checkbox"/>	<input type="checkbox"/>						
3	6	3			<input type="checkbox"/>	<input type="checkbox"/>	<input type="checkbox"/>	<input type="checkbox"/>	<input type="checkbox"/>	<input type="checkbox"/>	<input type="checkbox"/>	<input type="checkbox"/>			
3.2			0.3		<input type="checkbox"/>	<input type="checkbox"/>	<input type="checkbox"/>	<input type="checkbox"/>	<input type="checkbox"/>	<input type="checkbox"/>	<input type="checkbox"/>				
3.5	7				<input type="checkbox"/>	<input type="checkbox"/>	<input type="checkbox"/>	<input type="checkbox"/>	<input type="checkbox"/>	<input type="checkbox"/>	<input type="checkbox"/>	<input type="checkbox"/>	<input type="checkbox"/>		
3.7			0.3		<input type="checkbox"/>	<input type="checkbox"/>	<input type="checkbox"/>	<input type="checkbox"/>	<input type="checkbox"/>	<input type="checkbox"/>	<input type="checkbox"/>				
4	8				<input type="checkbox"/>	<input type="checkbox"/>	<input type="checkbox"/>	<input type="checkbox"/>	<input type="checkbox"/>	<input type="checkbox"/>	<input type="checkbox"/>	<input type="checkbox"/>	<input type="checkbox"/>		
4.2			0.3		<input type="checkbox"/>	<input type="checkbox"/>	<input type="checkbox"/>	<input type="checkbox"/>	<input type="checkbox"/>	<input type="checkbox"/>	<input type="checkbox"/>				
4.5					<input type="checkbox"/>	<input type="checkbox"/>	<input type="checkbox"/>	<input type="checkbox"/>	<input type="checkbox"/>	<input type="checkbox"/>	<input type="checkbox"/>	<input type="checkbox"/>	<input type="checkbox"/>		
5	10		0.3		<input type="checkbox"/>	<input type="checkbox"/>	<input type="checkbox"/>	<input type="checkbox"/>	<input type="checkbox"/>	<input type="checkbox"/>	<input type="checkbox"/>	<input type="checkbox"/>			
5.2					<input type="checkbox"/>	<input type="checkbox"/>	<input type="checkbox"/>	<input type="checkbox"/>	<input type="checkbox"/>	<input type="checkbox"/>	<input type="checkbox"/>	<input type="checkbox"/>	<input type="checkbox"/>	<input type="checkbox"/>	
5.5			0.3		<input type="checkbox"/>	<input type="checkbox"/>	<input type="checkbox"/>	<input type="checkbox"/>	<input type="checkbox"/>	<input type="checkbox"/>	<input type="checkbox"/>	<input type="checkbox"/>			
6	12	5			<input type="checkbox"/>	<input type="checkbox"/>	<input type="checkbox"/>	<input type="checkbox"/>	<input type="checkbox"/>	<input type="checkbox"/>	<input type="checkbox"/>	<input type="checkbox"/>	<input type="checkbox"/>	<input type="checkbox"/>	
6.2			0.5		<input type="checkbox"/>	<input type="checkbox"/>	<input type="checkbox"/>	<input type="checkbox"/>	<input type="checkbox"/>	<input type="checkbox"/>	<input type="checkbox"/>	<input type="checkbox"/>	<input type="checkbox"/>		
6.5					<input type="checkbox"/>	<input type="checkbox"/>	<input type="checkbox"/>	<input type="checkbox"/>	<input type="checkbox"/>	<input type="checkbox"/>	<input type="checkbox"/>	<input type="checkbox"/>	<input type="checkbox"/>	<input type="checkbox"/>	
7			0.5		<input type="checkbox"/>	<input type="checkbox"/>	<input type="checkbox"/>	<input type="checkbox"/>	<input type="checkbox"/>	<input type="checkbox"/>	<input type="checkbox"/>	<input type="checkbox"/>	<input type="checkbox"/>		
8	14				<input type="checkbox"/>	<input type="checkbox"/>	<input type="checkbox"/>	<input type="checkbox"/>	<input type="checkbox"/>	<input type="checkbox"/>	<input type="checkbox"/>	<input type="checkbox"/>	<input type="checkbox"/>	<input type="checkbox"/>	<input type="checkbox"/>
8.2			0.5		<input type="checkbox"/>	<input type="checkbox"/>	<input type="checkbox"/>	<input type="checkbox"/>	<input type="checkbox"/>	<input type="checkbox"/>	<input type="checkbox"/>	<input type="checkbox"/>	<input type="checkbox"/>	<input type="checkbox"/>	
8.5					<input type="checkbox"/>	<input type="checkbox"/>	<input type="checkbox"/>	<input type="checkbox"/>	<input type="checkbox"/>	<input type="checkbox"/>	<input type="checkbox"/>	<input type="checkbox"/>	<input type="checkbox"/>	<input type="checkbox"/>	<input type="checkbox"/>
9			0.5		<input type="checkbox"/>	<input type="checkbox"/>	<input type="checkbox"/>	<input type="checkbox"/>	<input type="checkbox"/>	<input type="checkbox"/>	<input type="checkbox"/>	<input type="checkbox"/>	<input type="checkbox"/>	<input type="checkbox"/>	
10	16				<input type="checkbox"/>	<input type="checkbox"/>	<input type="checkbox"/>	<input type="checkbox"/>	<input type="checkbox"/>	<input type="checkbox"/>	<input type="checkbox"/>	<input type="checkbox"/>	<input type="checkbox"/>	<input type="checkbox"/>	<input type="checkbox"/>
10.2			0.5		<input type="checkbox"/>	<input type="checkbox"/>	<input type="checkbox"/>	<input type="checkbox"/>	<input type="checkbox"/>	<input type="checkbox"/>	<input type="checkbox"/>	<input type="checkbox"/>	<input type="checkbox"/>	<input type="checkbox"/>	
10.5					<input type="checkbox"/>	<input type="checkbox"/>	<input type="checkbox"/>	<input type="checkbox"/>	<input type="checkbox"/>	<input type="checkbox"/>	<input type="checkbox"/>	<input type="checkbox"/>	<input type="checkbox"/>	<input type="checkbox"/>	<input type="checkbox"/>
11			0.5		<input type="checkbox"/>	<input type="checkbox"/>	<input type="checkbox"/>	<input type="checkbox"/>	<input type="checkbox"/>	<input type="checkbox"/>	<input type="checkbox"/>	<input type="checkbox"/>	<input type="checkbox"/>	<input type="checkbox"/>	
12	18	7			<input type="checkbox"/>	<input type="checkbox"/>	<input type="checkbox"/>	<input type="checkbox"/>	<input type="checkbox"/>	<input type="checkbox"/>	<input type="checkbox"/>	<input type="checkbox"/>	<input type="checkbox"/>	<input type="checkbox"/>	<input type="checkbox"/>
12.2			0.8		<input type="checkbox"/>	<input type="checkbox"/>	<input type="checkbox"/>	<input type="checkbox"/>	<input type="checkbox"/>	<input type="checkbox"/>	<input type="checkbox"/>	<input type="checkbox"/>	<input type="checkbox"/>	<input type="checkbox"/>	
12.5					<input type="checkbox"/>	<input type="checkbox"/>	<input type="checkbox"/>	<input type="checkbox"/>	<input type="checkbox"/>	<input type="checkbox"/>	<input type="checkbox"/>	<input type="checkbox"/>	<input type="checkbox"/>	<input type="checkbox"/>	<input type="checkbox"/>
14	22		0.8		<input type="checkbox"/>	<input type="checkbox"/>	<input type="checkbox"/>	<input type="checkbox"/>	<input type="checkbox"/>	<input type="checkbox"/>	<input type="checkbox"/>	<input type="checkbox"/>	<input type="checkbox"/>	<input type="checkbox"/>	
16					<input type="checkbox"/>	<input type="checkbox"/>	<input type="checkbox"/>	<input type="checkbox"/>	<input type="checkbox"/>	<input type="checkbox"/>	<input type="checkbox"/>	<input type="checkbox"/>	<input type="checkbox"/>	<input type="checkbox"/>	<input type="checkbox"/>
18	24		0.8		<input type="checkbox"/>	<input type="checkbox"/>	<input type="checkbox"/>	<input type="checkbox"/>	<input type="checkbox"/>	<input type="checkbox"/>	<input type="checkbox"/>	<input type="checkbox"/>	<input type="checkbox"/>	<input type="checkbox"/>	
20	26	8			<input type="checkbox"/>	<input type="checkbox"/>	<input type="checkbox"/>	<input type="checkbox"/>	<input type="checkbox"/>	<input type="checkbox"/>	<input type="checkbox"/>	<input type="checkbox"/>	<input type="checkbox"/>	<input type="checkbox"/>	<input type="checkbox"/>
25	32	10	1		<input type="checkbox"/>	<input type="checkbox"/>	<input type="checkbox"/>	<input type="checkbox"/>	<input type="checkbox"/>	<input type="checkbox"/>	<input type="checkbox"/>	<input type="checkbox"/>	<input type="checkbox"/>	<input type="checkbox"/>	
32	40				<input type="checkbox"/>	<input type="checkbox"/>	<input type="checkbox"/>	<input type="checkbox"/>	<input type="checkbox"/>	<input type="checkbox"/>	<input type="checkbox"/>	<input type="checkbox"/>	<input type="checkbox"/>	<input type="checkbox"/>	<input type="checkbox"/>

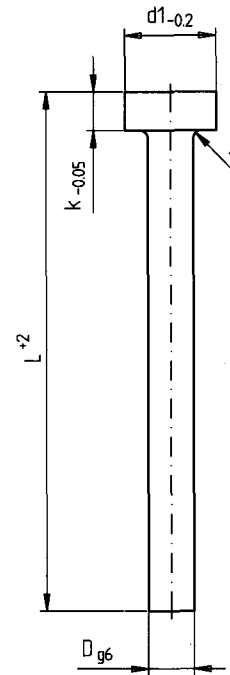

Warmarbeitsstahl

Härte :

Schaft > 950 HV 0.3  
Kopf 45 + 5 HRC  
Kern -1500 N/mm<sup>2</sup>

Stand 05.94

D	d1	k	L		40	60	80	100	125	160	200	250	315	400	500	630	800	1000	
			r	r															
15	3	15	0.2		<input type="checkbox"/>	<input type="checkbox"/>	<input type="checkbox"/>	<input type="checkbox"/>	<input type="checkbox"/>	<input type="checkbox"/>	<input type="checkbox"/>								
16					<input type="checkbox"/>	<input type="checkbox"/>	<input type="checkbox"/>	<input type="checkbox"/>	<input type="checkbox"/>	<input type="checkbox"/>	<input type="checkbox"/>	<input type="checkbox"/>	<input type="checkbox"/>						
2	4	2	0.3		<input type="checkbox"/>	<input type="checkbox"/>	<input type="checkbox"/>	<input type="checkbox"/>	<input type="checkbox"/>	<input type="checkbox"/>	<input type="checkbox"/>	<input type="checkbox"/>							
2.2					<input type="checkbox"/>	<input type="checkbox"/>	<input type="checkbox"/>	<input type="checkbox"/>	<input type="checkbox"/>	<input type="checkbox"/>	<input type="checkbox"/>	<input type="checkbox"/>	<input type="checkbox"/>	<input type="checkbox"/>					
2.5	5		0.3		<input type="checkbox"/>	<input type="checkbox"/>	<input type="checkbox"/>	<input type="checkbox"/>	<input type="checkbox"/>	<input type="checkbox"/>	<input type="checkbox"/>	<input type="checkbox"/>							
2.7					<input type="checkbox"/>	<input type="checkbox"/>	<input type="checkbox"/>	<input type="checkbox"/>	<input type="checkbox"/>	<input type="checkbox"/>	<input type="checkbox"/>	<input type="checkbox"/>	<input type="checkbox"/>	<input type="checkbox"/>					
3	6	3	0.3		<input type="checkbox"/>	<input type="checkbox"/>	<input type="checkbox"/>	<input type="checkbox"/>	<input type="checkbox"/>	<input type="checkbox"/>	<input type="checkbox"/>	<input type="checkbox"/>	<input type="checkbox"/>	<input type="checkbox"/>					
3.2					<input type="checkbox"/>	<input type="checkbox"/>	<input type="checkbox"/>	<input type="checkbox"/>	<input type="checkbox"/>	<input type="checkbox"/>	<input type="checkbox"/>	<input type="checkbox"/>	<input type="checkbox"/>	<input type="checkbox"/>	<input type="checkbox"/>	<input type="checkbox"/>			
3.5	7		0.3		<input type="checkbox"/>	<input type="checkbox"/>	<input type="checkbox"/>	<input type="checkbox"/>	<input type="checkbox"/>	<input type="checkbox"/>	<input type="checkbox"/>	<input type="checkbox"/>	<input type="checkbox"/>	<input type="checkbox"/>	<input type="checkbox"/>				
3.7					<input type="checkbox"/>	<input type="checkbox"/>	<input type="checkbox"/>	<input type="checkbox"/>	<input type="checkbox"/>	<input type="checkbox"/>	<input type="checkbox"/>	<input type="checkbox"/>	<input type="checkbox"/>	<input type="checkbox"/>	<input type="checkbox"/>	<input type="checkbox"/>	<input type="checkbox"/>		
4	8		0.3		<input type="checkbox"/>	<input type="checkbox"/>	<input type="checkbox"/>	<input type="checkbox"/>	<input type="checkbox"/>	<input type="checkbox"/>	<input type="checkbox"/>	<input type="checkbox"/>	<input type="checkbox"/>	<input type="checkbox"/>	<input type="checkbox"/>	<input type="checkbox"/>			
4.2					<input type="checkbox"/>	<input type="checkbox"/>	<input type="checkbox"/>	<input type="checkbox"/>	<input type="checkbox"/>	<input type="checkbox"/>	<input type="checkbox"/>	<input type="checkbox"/>	<input type="checkbox"/>	<input type="checkbox"/>	<input type="checkbox"/>	<input type="checkbox"/>	<input type="checkbox"/>	<input type="checkbox"/>	
4.5			0.3		<input type="checkbox"/>	<input type="checkbox"/>	<input type="checkbox"/>	<input type="checkbox"/>	<input type="checkbox"/>	<input type="checkbox"/>	<input type="checkbox"/>	<input type="checkbox"/>	<input type="checkbox"/>	<input type="checkbox"/>	<input type="checkbox"/>	<input type="checkbox"/>	<input type="checkbox"/>		
4.7					<input type="checkbox"/>	<input type="checkbox"/>	<input type="checkbox"/>	<input type="checkbox"/>	<input type="checkbox"/>	<input type="checkbox"/>	<input type="checkbox"/>	<input type="checkbox"/>	<input type="checkbox"/>	<input type="checkbox"/>	<input type="checkbox"/>	<input type="checkbox"/>	<input type="checkbox"/>	<input type="checkbox"/>	<input type="checkbox"/>
5	10		0.3		<input type="checkbox"/>	<input type="checkbox"/>	<input type="checkbox"/>	<input type="checkbox"/>	<input type="checkbox"/>	<input type="checkbox"/>	<input type="checkbox"/>	<input type="checkbox"/>	<input type="checkbox"/>	<input type="checkbox"/>	<input type="checkbox"/>	<input type="checkbox"/>	<input type="checkbox"/>	<input type="checkbox"/>	
5.2					<input type="checkbox"/>	<input type="checkbox"/>	<input type="checkbox"/>	<input type="checkbox"/>	<input type="checkbox"/>	<input type="checkbox"/>	<input type="checkbox"/>	<input type="checkbox"/>	<input type="checkbox"/>	<input type="checkbox"/>	<input type="checkbox"/>	<input type="checkbox"/>	<input type="checkbox"/>	<input type="checkbox"/>	<input type="checkbox"/>
5.5			0.3		<input type="checkbox"/>	<input type="checkbox"/>	<input type="checkbox"/>	<input type="checkbox"/>	<input type="checkbox"/>	<input type="checkbox"/>	<input type="checkbox"/>	<input type="checkbox"/>	<input type="checkbox"/>	<input type="checkbox"/>	<input type="checkbox"/>	<input type="checkbox"/>	<input type="checkbox"/>	<input type="checkbox"/>	
6	12	5			<input type="checkbox"/>	<input type="checkbox"/>	<input type="checkbox"/>	<input type="checkbox"/>	<input type="checkbox"/>	<input type="checkbox"/>	<input type="checkbox"/>	<input type="checkbox"/>	<input type="checkbox"/>	<input type="checkbox"/>	<input type="checkbox"/>	<input type="checkbox"/>	<input type="checkbox"/>	<input type="checkbox"/>	<input type="checkbox"/>
6.2			0.5		<input type="checkbox"/>	<input type="checkbox"/>	<input type="checkbox"/>	<input type="checkbox"/>	<input type="checkbox"/>	<input type="checkbox"/>	<input type="checkbox"/>	<input type="checkbox"/>	<input type="checkbox"/>	<input type="checkbox"/>	<input type="checkbox"/>	<input type="checkbox"/>	<input type="checkbox"/>	<input type="checkbox"/>	
6.5					<input type="checkbox"/>	<input type="checkbox"/>	<input type="checkbox"/>	<input type="checkbox"/>	<input type="checkbox"/>	<input type="checkbox"/>	<input type="checkbox"/>	<input type="checkbox"/>	<input type="checkbox"/>	<input type="checkbox"/>	<input type="checkbox"/>	<input type="checkbox"/>	<input type="checkbox"/>	<input type="checkbox"/>	<input type="checkbox"/>
7			0.5		<input type="checkbox"/>	<input type="checkbox"/>	<input type="checkbox"/>	<input type="checkbox"/>	<input type="checkbox"/>	<input type="checkbox"/>	<input type="checkbox"/>	<input type="checkbox"/>	<input type="checkbox"/>	<input type="checkbox"/>	<input type="checkbox"/>	<input type="checkbox"/>	<input type="checkbox"/>	<input type="checkbox"/>	
8	14				<input type="checkbox"/>	<input type="checkbox"/>	<input type="checkbox"/>	<input type="checkbox"/>	<input type="checkbox"/>	<input type="checkbox"/>	<input type="checkbox"/>	<input type="checkbox"/>	<input type="checkbox"/>	<input type="checkbox"/>	<input type="checkbox"/>	<input type="checkbox"/>	<input type="checkbox"/>	<input type="checkbox"/>	<input type="checkbox"/>
8.2			0.5		<input type="checkbox"/>	<input type="checkbox"/>	<input type="checkbox"/>	<input type="checkbox"/>	<input type="checkbox"/>	<input type="checkbox"/>	<input type="checkbox"/>	<input type="checkbox"/>	<input type="checkbox"/>	<input type="checkbox"/>	<input type="checkbox"/>	<input type="checkbox"/>	<input type="checkbox"/>	<input type="checkbox"/>	
8.5					<input type="checkbox"/>	<input type="checkbox"/>	<input type="checkbox"/>	<input type="checkbox"/>	<input type="checkbox"/>	<input type="checkbox"/>	<input type="checkbox"/>	<input type="checkbox"/>	<input type="checkbox"/>	<input type="checkbox"/>	<input type="checkbox"/>	<input type="checkbox"/>	<input type="checkbox"/>	<input type="checkbox"/>	<input type="checkbox"/>
9			0.5		<input type="checkbox"/>	<input type="checkbox"/>	<input type="checkbox"/>	<input type="checkbox"/>	<input type="checkbox"/>	<input type="checkbox"/>	<input type="checkbox"/>	<input type="checkbox"/>	<input type="checkbox"/>	<input type="checkbox"/>	<input type="checkbox"/>	<input type="checkbox"/>	<input type="checkbox"/>	<input type="checkbox"/>	
10	16				<input type="checkbox"/>	<input type="checkbox"/>	<input type="checkbox"/>	<input type="checkbox"/>	<input type="checkbox"/>	<input type="checkbox"/>	<input type="checkbox"/>	<input type="checkbox"/>	<input type="checkbox"/>	<input type="checkbox"/>	<input type="checkbox"/>	<input type="checkbox"/>	<input type="checkbox"/>	<input type="checkbox"/>	<input type="checkbox"/>
10.2			0.5		<input type="checkbox"/>	<input type="checkbox"/>	<input type="checkbox"/>	<input type="checkbox"/>	<input type="checkbox"/>	<input type="checkbox"/>	<input type="checkbox"/>	<input type="checkbox"/>	<input type="checkbox"/>	<input type="checkbox"/>	<input type="checkbox"/>	<input type="checkbox"/>	<input type="checkbox"/>	<input type="checkbox"/>	
10.5					<input type="checkbox"/>	<input type="checkbox"/>	<input type="checkbox"/>	<input type="checkbox"/>	<input type="checkbox"/>	<input type="checkbox"/>	<input type="checkbox"/>	<input type="checkbox"/>	<input type="checkbox"/>	<input type="checkbox"/>	<input type="checkbox"/>	<input type="checkbox"/>	<input type="checkbox"/>	<input type="checkbox"/>	<input type="checkbox"/>
11			0.5		<input type="checkbox"/>	<input type="checkbox"/>	<input type="checkbox"/>	<input type="checkbox"/>	<input type="checkbox"/>	<input type="checkbox"/>	<input type="checkbox"/>	<input type="checkbox"/>	<input type="checkbox"/>	<input type="checkbox"/>	<input type="checkbox"/>	<input type="checkbox"/>	<input type="checkbox"/>	<input type="checkbox"/>	
12	18	7			<input type="checkbox"/>	<input type="checkbox"/>	<input type="checkbox"/>	<input type="checkbox"/>	<input type="checkbox"/>	<input type="checkbox"/>	<input type="checkbox"/>	<input type="checkbox"/>	<input type="checkbox"/>	<input type="checkbox"/>	<input type="checkbox"/>	<input type="checkbox"/>	<input type="checkbox"/>	<input type="checkbox"/>	<input type="checkbox"/>
12.2			0.8		<input type="checkbox"/>	<input type="checkbox"/>	<input type="checkbox"/>	<input type="checkbox"/>	<input type="checkbox"/>	<input type="checkbox"/>	<input type="checkbox"/>	<input type="checkbox"/>	<input type="checkbox"/>	<input type="checkbox"/>	<input type="checkbox"/>	<input type="checkbox"/>	<input type="checkbox"/>	<input type="checkbox"/>	
12.5					<input type="checkbox"/>	<input type="checkbox"/>	<input type="checkbox"/>	<input type="checkbox"/>	<input type="checkbox"/>	<input type="checkbox"/>	<input type="checkbox"/>	<input type="checkbox"/>	<input type="checkbox"/>	<input type="checkbox"/>	<input type="checkbox"/>	<input type="checkbox"/>	<input type="checkbox"/>	<input type="checkbox"/>	<input type="checkbox"/>
14	22		0.8		<input type="checkbox"/>	<input type="checkbox"/>	<input type="checkbox"/>	<input type="checkbox"/>	<input type="checkbox"/>	<input type="checkbox"/>	<input type="checkbox"/>	<input type="checkbox"/>	<input type="checkbox"/>	<input type="checkbox"/>	<input type="checkbox"/>	<input type="checkbox"/>	<input type="checkbox"/>	<input type="checkbox"/>	
16					<input type="checkbox"/>	<input type="checkbox"/>	<input type="checkbox"/>	<input type="checkbox"/>	<input type="checkbox"/>	<input type="checkbox"/>	<input type="checkbox"/>	<input type="checkbox"/>	<input type="checkbox"/>	<input type="checkbox"/>	<input type="checkbox"/>	<input type="checkbox"/>	<input type="checkbox"/>	<input type="checkbox"/>	<input type="checkbox"/>
18	24		0.8		<input type="checkbox"/>	<input type="checkbox"/>	<input type="checkbox"/>	<input type="checkbox"/>	<input type="checkbox"/>	<input type="checkbox"/>	<input type="checkbox"/>	<input type="checkbox"/>	<input type="checkbox"/>	<input type="checkbox"/>	<input type="checkbox"/>	<input type="checkbox"/>	<input type="checkbox"/>	<input type="checkbox"/>	
20	26	8			<input type="checkbox"/>	<input type="checkbox"/>	<input type="checkbox"/>	<input type="checkbox"/>	<input type="checkbox"/>	<input type="checkbox"/>	<input type="checkbox"/>	<input type="checkbox"/>	<input type="checkbox"/>	<input type="checkbox"/>	<input type="checkbox"/>	<input type="checkbox"/>	<input type="checkbox"/>	<input type="checkbox"/>	<input type="checkbox"/>

## R201/DxL

gehärtet  
DIN 1530-AH

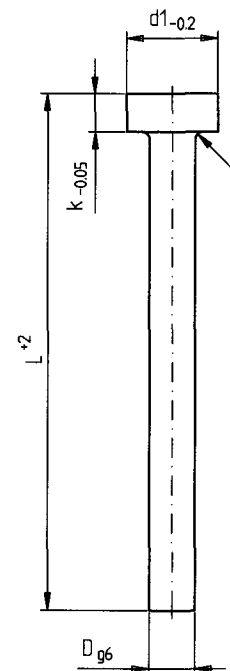

legierter  
Werkzeugstahl

Härte :

Schaft 62 ± 2 HRC  
Kopf 45 ± 5 HRC

## R21/DxL

gehärtet  
DIN 1530-D

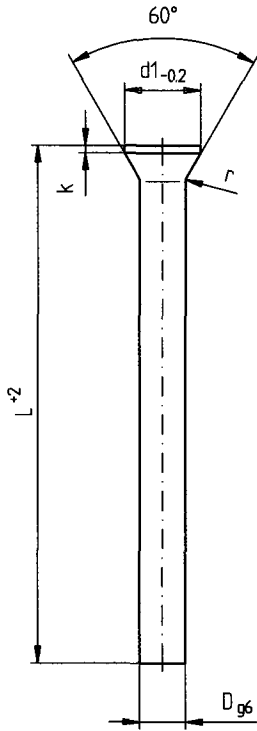

D	d1	k	L												
			40	60	80	100	125	160	200	250	315				
1	18	0.5	<input type="checkbox"/>	<input type="checkbox"/>	<input type="checkbox"/>	<input type="checkbox"/>	<input type="checkbox"/>	<input type="checkbox"/>	<input type="checkbox"/>	<input type="checkbox"/>	<input type="checkbox"/>	<input type="checkbox"/>	<input type="checkbox"/>	<input type="checkbox"/>	<input type="checkbox"/>
1.1						<input type="checkbox"/>	<input type="checkbox"/>	<input type="checkbox"/>	<input type="checkbox"/>	<input type="checkbox"/>	<input type="checkbox"/>	<input type="checkbox"/>	<input type="checkbox"/>	<input type="checkbox"/>	<input type="checkbox"/>
1.2	2					<input type="checkbox"/>	<input type="checkbox"/>	<input type="checkbox"/>	<input type="checkbox"/>	<input type="checkbox"/>	<input type="checkbox"/>	<input type="checkbox"/>	<input type="checkbox"/>	<input type="checkbox"/>	<input type="checkbox"/>
1.25						<input type="checkbox"/>	<input type="checkbox"/>	<input type="checkbox"/>	<input type="checkbox"/>	<input type="checkbox"/>	<input type="checkbox"/>	<input type="checkbox"/>	<input type="checkbox"/>	<input type="checkbox"/>	<input type="checkbox"/>
1.3						<input type="checkbox"/>	<input type="checkbox"/>	<input type="checkbox"/>	<input type="checkbox"/>	<input type="checkbox"/>	<input type="checkbox"/>	<input type="checkbox"/>	<input type="checkbox"/>	<input type="checkbox"/>	<input type="checkbox"/>
1.4	2.2					<input type="checkbox"/>	<input type="checkbox"/>	<input type="checkbox"/>	<input type="checkbox"/>	<input type="checkbox"/>	<input type="checkbox"/>	<input type="checkbox"/>	<input type="checkbox"/>	<input type="checkbox"/>	<input type="checkbox"/>
1.5			<input type="checkbox"/>	<input type="checkbox"/>	<input type="checkbox"/>	<input type="checkbox"/>	<input type="checkbox"/>	<input type="checkbox"/>	<input type="checkbox"/>	<input type="checkbox"/>	<input type="checkbox"/>	<input type="checkbox"/>	<input type="checkbox"/>	<input type="checkbox"/>	<input type="checkbox"/>
1.6	2.5					<input type="checkbox"/>	<input type="checkbox"/>	<input type="checkbox"/>	<input type="checkbox"/>	<input type="checkbox"/>	<input type="checkbox"/>	<input type="checkbox"/>	<input type="checkbox"/>	<input type="checkbox"/>	<input type="checkbox"/>
1.7						<input type="checkbox"/>	<input type="checkbox"/>	<input type="checkbox"/>	<input type="checkbox"/>	<input type="checkbox"/>	<input type="checkbox"/>	<input type="checkbox"/>	<input type="checkbox"/>	<input type="checkbox"/>	<input type="checkbox"/>
1.75	2.8					<input type="checkbox"/>	<input type="checkbox"/>	<input type="checkbox"/>	<input type="checkbox"/>	<input type="checkbox"/>	<input type="checkbox"/>	<input type="checkbox"/>	<input type="checkbox"/>	<input type="checkbox"/>	<input type="checkbox"/>
1.8						<input type="checkbox"/>	<input type="checkbox"/>	<input type="checkbox"/>	<input type="checkbox"/>	<input type="checkbox"/>	<input type="checkbox"/>	<input type="checkbox"/>	<input type="checkbox"/>	<input type="checkbox"/>	<input type="checkbox"/>
1.9						<input type="checkbox"/>	<input type="checkbox"/>	<input type="checkbox"/>	<input type="checkbox"/>	<input type="checkbox"/>	<input type="checkbox"/>	<input type="checkbox"/>	<input type="checkbox"/>	<input type="checkbox"/>	<input type="checkbox"/>
2	3		<input type="checkbox"/>	<input type="checkbox"/>	<input type="checkbox"/>	<input type="checkbox"/>	<input type="checkbox"/>	<input type="checkbox"/>	<input type="checkbox"/>	<input type="checkbox"/>	<input type="checkbox"/>	<input type="checkbox"/>	<input type="checkbox"/>	<input type="checkbox"/>	<input type="checkbox"/>
2.1	3.2					<input type="checkbox"/>	<input type="checkbox"/>	<input type="checkbox"/>	<input type="checkbox"/>	<input type="checkbox"/>	<input type="checkbox"/>	<input type="checkbox"/>	<input type="checkbox"/>	<input type="checkbox"/>	<input type="checkbox"/>
2.2						<input type="checkbox"/>	<input type="checkbox"/>	<input type="checkbox"/>	<input type="checkbox"/>	<input type="checkbox"/>	<input type="checkbox"/>	<input type="checkbox"/>	<input type="checkbox"/>	<input type="checkbox"/>	<input type="checkbox"/>
2.25	3.5					<input type="checkbox"/>	<input type="checkbox"/>	<input type="checkbox"/>	<input type="checkbox"/>	<input type="checkbox"/>	<input type="checkbox"/>	<input type="checkbox"/>	<input type="checkbox"/>	<input type="checkbox"/>	<input type="checkbox"/>
2.3						<input type="checkbox"/>	<input type="checkbox"/>	<input type="checkbox"/>	<input type="checkbox"/>	<input type="checkbox"/>	<input type="checkbox"/>	<input type="checkbox"/>	<input type="checkbox"/>	<input type="checkbox"/>	<input type="checkbox"/>
2.4						<input type="checkbox"/>	<input type="checkbox"/>	<input type="checkbox"/>	<input type="checkbox"/>	<input type="checkbox"/>	<input type="checkbox"/>	<input type="checkbox"/>	<input type="checkbox"/>	<input type="checkbox"/>	<input type="checkbox"/>
2.5			<input type="checkbox"/>	<input type="checkbox"/>	<input type="checkbox"/>	<input type="checkbox"/>	<input type="checkbox"/>	<input type="checkbox"/>	<input type="checkbox"/>	<input type="checkbox"/>	<input type="checkbox"/>	<input type="checkbox"/>	<input type="checkbox"/>	<input type="checkbox"/>	<input type="checkbox"/>
2.6	4					<input type="checkbox"/>	<input type="checkbox"/>	<input type="checkbox"/>	<input type="checkbox"/>	<input type="checkbox"/>	<input type="checkbox"/>	<input type="checkbox"/>	<input type="checkbox"/>	<input type="checkbox"/>	<input type="checkbox"/>
2.7						<input type="checkbox"/>	<input type="checkbox"/>	<input type="checkbox"/>	<input type="checkbox"/>	<input type="checkbox"/>	<input type="checkbox"/>	<input type="checkbox"/>	<input type="checkbox"/>	<input type="checkbox"/>	<input type="checkbox"/>
2.75						<input type="checkbox"/>	<input type="checkbox"/>	<input type="checkbox"/>	<input type="checkbox"/>	<input type="checkbox"/>	<input type="checkbox"/>	<input type="checkbox"/>	<input type="checkbox"/>	<input type="checkbox"/>	<input type="checkbox"/>
2.8						<input type="checkbox"/>	<input type="checkbox"/>	<input type="checkbox"/>	<input type="checkbox"/>	<input type="checkbox"/>	<input type="checkbox"/>	<input type="checkbox"/>	<input type="checkbox"/>	<input type="checkbox"/>	<input type="checkbox"/>
2.9						<input type="checkbox"/>	<input type="checkbox"/>	<input type="checkbox"/>	<input type="checkbox"/>	<input type="checkbox"/>	<input type="checkbox"/>	<input type="checkbox"/>	<input type="checkbox"/>	<input type="checkbox"/>	<input type="checkbox"/>
3	4.5		<input type="checkbox"/>	<input type="checkbox"/>	<input type="checkbox"/>	<input type="checkbox"/>	<input type="checkbox"/>	<input type="checkbox"/>	<input type="checkbox"/>	<input type="checkbox"/>	<input type="checkbox"/>	<input type="checkbox"/>	<input type="checkbox"/>	<input type="checkbox"/>	<input type="checkbox"/>
3.1						<input type="checkbox"/>	<input type="checkbox"/>	<input type="checkbox"/>	<input type="checkbox"/>	<input type="checkbox"/>	<input type="checkbox"/>	<input type="checkbox"/>	<input type="checkbox"/>	<input type="checkbox"/>	<input type="checkbox"/>
3.2						<input type="checkbox"/>	<input type="checkbox"/>	<input type="checkbox"/>	<input type="checkbox"/>	<input type="checkbox"/>	<input type="checkbox"/>	<input type="checkbox"/>	<input type="checkbox"/>	<input type="checkbox"/>	<input type="checkbox"/>
3.25						<input type="checkbox"/>	<input type="checkbox"/>	<input type="checkbox"/>	<input type="checkbox"/>	<input type="checkbox"/>	<input type="checkbox"/>	<input type="checkbox"/>	<input type="checkbox"/>	<input type="checkbox"/>	<input type="checkbox"/>
3.5	5				<input type="checkbox"/>	<input type="checkbox"/>	<input type="checkbox"/>	<input type="checkbox"/>	<input type="checkbox"/>	<input type="checkbox"/>	<input type="checkbox"/>	<input type="checkbox"/>	<input type="checkbox"/>	<input type="checkbox"/>	<input type="checkbox"/>
3.6						<input type="checkbox"/>	<input type="checkbox"/>	<input type="checkbox"/>	<input type="checkbox"/>	<input type="checkbox"/>	<input type="checkbox"/>	<input type="checkbox"/>	<input type="checkbox"/>	<input type="checkbox"/>	<input type="checkbox"/>
3.75						<input type="checkbox"/>	<input type="checkbox"/>	<input type="checkbox"/>	<input type="checkbox"/>	<input type="checkbox"/>	<input type="checkbox"/>	<input type="checkbox"/>	<input type="checkbox"/>	<input type="checkbox"/>	<input type="checkbox"/>
4	5.5		<input type="checkbox"/>	<input type="checkbox"/>	<input type="checkbox"/>	<input type="checkbox"/>	<input type="checkbox"/>	<input type="checkbox"/>	<input type="checkbox"/>	<input type="checkbox"/>	<input type="checkbox"/>	<input type="checkbox"/>	<input type="checkbox"/>	<input type="checkbox"/>	<input type="checkbox"/>
4.1						<input type="checkbox"/>	<input type="checkbox"/>	<input type="checkbox"/>	<input type="checkbox"/>	<input type="checkbox"/>	<input type="checkbox"/>	<input type="checkbox"/>	<input type="checkbox"/>	<input type="checkbox"/>	<input type="checkbox"/>
4.2						<input type="checkbox"/>	<input type="checkbox"/>	<input type="checkbox"/>	<input type="checkbox"/>	<input type="checkbox"/>	<input type="checkbox"/>	<input type="checkbox"/>	<input type="checkbox"/>	<input type="checkbox"/>	<input type="checkbox"/>
4.25						<input type="checkbox"/>	<input type="checkbox"/>	<input type="checkbox"/>	<input type="checkbox"/>	<input type="checkbox"/>	<input type="checkbox"/>	<input type="checkbox"/>	<input type="checkbox"/>	<input type="checkbox"/>	<input type="checkbox"/>
4.5	6					<input type="checkbox"/>	<input type="checkbox"/>	<input type="checkbox"/>	<input type="checkbox"/>	<input type="checkbox"/>	<input type="checkbox"/>	<input type="checkbox"/>	<input type="checkbox"/>	<input type="checkbox"/>	<input type="checkbox"/>
4.6						<input type="checkbox"/>	<input type="checkbox"/>	<input type="checkbox"/>	<input type="checkbox"/>	<input type="checkbox"/>	<input type="checkbox"/>	<input type="checkbox"/>	<input type="checkbox"/>	<input type="checkbox"/>	<input type="checkbox"/>
5	6.5		<input type="checkbox"/>	<input type="checkbox"/>	<input type="checkbox"/>	<input type="checkbox"/>	<input type="checkbox"/>	<input type="checkbox"/>	<input type="checkbox"/>	<input type="checkbox"/>	<input type="checkbox"/>	<input type="checkbox"/>	<input type="checkbox"/>	<input type="checkbox"/>	<input type="checkbox"/>
5.1						<input type="checkbox"/>	<input type="checkbox"/>	<input type="checkbox"/>	<input type="checkbox"/>	<input type="checkbox"/>	<input type="checkbox"/>	<input type="checkbox"/>	<input type="checkbox"/>	<input type="checkbox"/>	<input type="checkbox"/>
5.2						<input type="checkbox"/>	<input type="checkbox"/>	<input type="checkbox"/>	<input type="checkbox"/>	<input type="checkbox"/>	<input type="checkbox"/>	<input type="checkbox"/>	<input type="checkbox"/>	<input type="checkbox"/>	<input type="checkbox"/>
5.25						<input type="checkbox"/>	<input type="checkbox"/>	<input type="checkbox"/>	<input type="checkbox"/>	<input type="checkbox"/>	<input type="checkbox"/>	<input type="checkbox"/>	<input type="checkbox"/>	<input type="checkbox"/>	<input type="checkbox"/>
5.5	7		<input type="checkbox"/>	<input type="checkbox"/>	<input type="checkbox"/>	<input type="checkbox"/>	<input type="checkbox"/>	<input type="checkbox"/>	<input type="checkbox"/>	<input type="checkbox"/>	<input type="checkbox"/>	<input type="checkbox"/>	<input type="checkbox"/>	<input type="checkbox"/>	<input type="checkbox"/>
6	8		<input type="checkbox"/>	<input type="checkbox"/>	<input type="checkbox"/>	<input type="checkbox"/>	<input type="checkbox"/>	<input type="checkbox"/>	<input type="checkbox"/>	<input type="checkbox"/>	<input type="checkbox"/>	<input type="checkbox"/>	<input type="checkbox"/>	<input type="checkbox"/>	<input type="checkbox"/>
6.2						<input type="checkbox"/>	<input type="checkbox"/>	<input type="checkbox"/>	<input type="checkbox"/>	<input type="checkbox"/>	<input type="checkbox"/>	<input type="checkbox"/>	<input type="checkbox"/>	<input type="checkbox"/>	<input type="checkbox"/>
6.5	9	1				<input type="checkbox"/>	<input type="checkbox"/>	<input type="checkbox"/>	<input type="checkbox"/>	<input type="checkbox"/>	<input type="checkbox"/>	<input type="checkbox"/>	<input type="checkbox"/>	<input type="checkbox"/>	<input type="checkbox"/>
7						<input type="checkbox"/>	<input type="checkbox"/>	<input type="checkbox"/>	<input type="checkbox"/>	<input type="checkbox"/>	<input type="checkbox"/>	<input type="checkbox"/>	<input type="checkbox"/>	<input type="checkbox"/>	<input type="checkbox"/>
7.5	10					<input type="checkbox"/>	<input type="checkbox"/>	<input type="checkbox"/>	<input type="checkbox"/>	<input type="checkbox"/>	<input type="checkbox"/>	<input type="checkbox"/>	<input type="checkbox"/>	<input type="checkbox"/>	<input type="checkbox"/>
8			<input type="checkbox"/>	<input type="checkbox"/>	<input type="checkbox"/>	<input type="checkbox"/>	<input type="checkbox"/>	<input type="checkbox"/>	<input type="checkbox"/>	<input type="checkbox"/>	<input type="checkbox"/>	<input type="checkbox"/>	<input type="checkbox"/>	<input type="checkbox"/>	<input type="checkbox"/>
8.2						<input type="checkbox"/>	<input type="checkbox"/>	<input type="checkbox"/>	<input type="checkbox"/>	<input type="checkbox"/>	<input type="checkbox"/>	<input type="checkbox"/>	<input type="checkbox"/>	<input type="checkbox"/>	<input type="checkbox"/>
8.5	11					<input type="checkbox"/>	<input type="checkbox"/>	<input type="checkbox"/>	<input type="checkbox"/>	<input type="checkbox"/>	<input type="checkbox"/>	<input type="checkbox"/>	<input type="checkbox"/>	<input type="checkbox"/>	<input type="checkbox"/>
9						<input type="checkbox"/>	<input type="checkbox"/>	<input type="checkbox"/>	<input type="checkbox"/>	<input type="checkbox"/>	<input type="checkbox"/>	<input type="checkbox"/>	<input type="checkbox"/>	<input type="checkbox"/>	<input type="checkbox"/>
10	12		<input type="checkbox"/>	<input type="checkbox"/>	<input type="checkbox"/>	<input type="checkbox"/>	<input type="checkbox"/>	<input type="checkbox"/>	<input type="checkbox"/>	<input type="checkbox"/>	<input type="checkbox"/>	<input type="checkbox"/>	<input type="checkbox"/>	<input type="checkbox"/>	<input type="checkbox"/>
12	14					<input type="checkbox"/>	<input type="checkbox"/>	<input type="checkbox"/>	<input type="checkbox"/>	<input type="checkbox"/>	<input type="checkbox"/>	<input type="checkbox"/>	<input type="checkbox"/>	<input type="checkbox"/>	<input type="checkbox"/>
14	16	15				<input type="checkbox"/>	<input type="checkbox"/>	<input type="checkbox"/>	<input type="checkbox"/>	<input type="checkbox"/>	<input type="checkbox"/>	<input type="checkbox"/>	<input type="checkbox"/>	<input type="checkbox"/>	<input type="checkbox"/>
16	18					<input type="checkbox"/>	<input type="checkbox"/>	<input type="checkbox"/>	<input type="checkbox"/>	<input type="checkbox"/>	<input type="checkbox"/>	<input type="checkbox"/>	<input type="checkbox"/>	<input type="checkbox"/>	<input type="checkbox"/>

legierter  
Werkzeugstahl

Härte :

Schaft 62 ± 2 HRC  
Kopf 45 ± 5 HRC

## R22/DxL

gasnitriert  
DIN 1530-C

D	d1	d2	k	L							
				l1	80	100	125	150	160	200	
0.8	2	4	2								
0.9											
1											
1.1											
1.2											
1.3											
1.4											
1.5	3	6	3								
1.6											
1.7											
1.8											
1.9											
2											
2.2											
2.5											

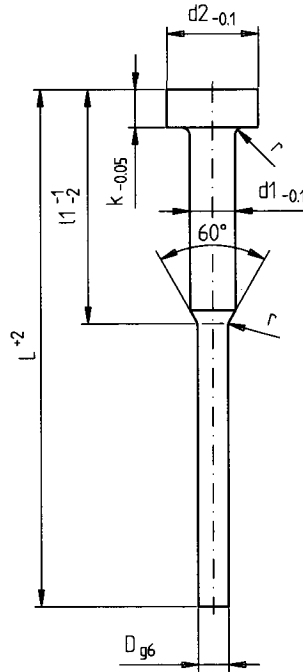

Warmarbeitsstahl

Härte :

Schaft > 950 HV 0.3  
Kopf 45 + 5 HRC  
Kern < -1500 N/mm<sup>2</sup>

Stand 05.94

## R221/DxL

gehärtet  
DIN 1530-CH

D	d1	d2	k	L									
				l1	60	80	100	125	150	160	200	250	
0.8	2	4	2										
0.9													
1													
1.1													
1.2													
1.3													
1.4													
1.5	3	6	3										
1.6													
1.7													
1.8													
1.9													
2													
2.1													
2.2													
2.3													
2.4													
2.5													

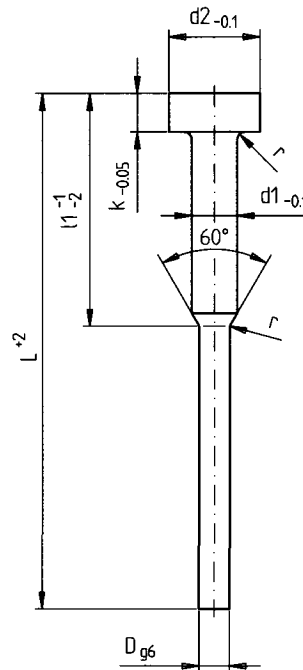

legierter  
Werkzeugstahl

Härte :

Schaft 62 ± 2 HRC  
Kopf 45 ± 5 HRC

## R24/DxBxL

gasnitriert  
DIN 16756

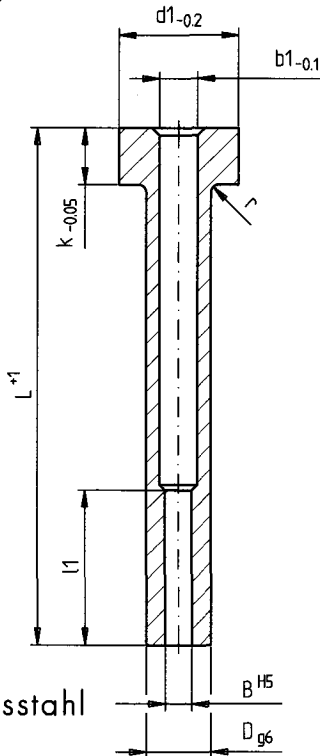

D	B	b1	d1	k	r	L1	L																
							75	80	95	100	110	125	150	175	200	225	250	275					
3	16	19	6	3	0.3	35	<input type="checkbox"/>					<input type="checkbox"/>	<input type="checkbox"/>										
	15	8					20	<input type="checkbox"/>	<input type="checkbox"/>	<input type="checkbox"/>													
4	2		2.4	10	5	0.5	35	<input type="checkbox"/>		<input type="checkbox"/>	<input type="checkbox"/>	<input type="checkbox"/>	<input type="checkbox"/>										
	2.2		<input type="checkbox"/>					<input type="checkbox"/>	<input type="checkbox"/>	<input type="checkbox"/>													
	2.5	3	<input type="checkbox"/>						<input type="checkbox"/>	<input type="checkbox"/>	<input type="checkbox"/>												
	2.7		<input type="checkbox"/>						<input type="checkbox"/>	<input type="checkbox"/>	<input type="checkbox"/>												
5	3	3.3	12	7	0.8	45	<input type="checkbox"/>		<input type="checkbox"/>	<input type="checkbox"/>	<input type="checkbox"/>	<input type="checkbox"/>											
	3.2	3.5					<input type="checkbox"/>	<input type="checkbox"/>	<input type="checkbox"/>	<input type="checkbox"/>	<input type="checkbox"/>												
	3.5	4					<input type="checkbox"/>	<input type="checkbox"/>	<input type="checkbox"/>	<input type="checkbox"/>	<input type="checkbox"/>												
	3.7						<input type="checkbox"/>	<input type="checkbox"/>	<input type="checkbox"/>	<input type="checkbox"/>	<input type="checkbox"/>												
6	4	4.3	14	5	0.5	45	<input type="checkbox"/>		<input type="checkbox"/>	<input type="checkbox"/>	<input type="checkbox"/>	<input type="checkbox"/>											
	4.2	5					<input type="checkbox"/>	<input type="checkbox"/>	<input type="checkbox"/>	<input type="checkbox"/>	<input type="checkbox"/>												
	5	5.3					<input type="checkbox"/>	<input type="checkbox"/>	<input type="checkbox"/>	<input type="checkbox"/>	<input type="checkbox"/>												
	5.2	5.5					<input type="checkbox"/>	<input type="checkbox"/>	<input type="checkbox"/>	<input type="checkbox"/>	<input type="checkbox"/>												
8	6	6.3	16	7	0.8	45	<input type="checkbox"/>		<input type="checkbox"/>	<input type="checkbox"/>	<input type="checkbox"/>	<input type="checkbox"/>											
	6.2	6.5					<input type="checkbox"/>	<input type="checkbox"/>	<input type="checkbox"/>	<input type="checkbox"/>	<input type="checkbox"/>												
	8	8.3					<input type="checkbox"/>	<input type="checkbox"/>	<input type="checkbox"/>	<input type="checkbox"/>	<input type="checkbox"/>												
	8.2	8.5					<input type="checkbox"/>	<input type="checkbox"/>	<input type="checkbox"/>	<input type="checkbox"/>	<input type="checkbox"/>												
10	10	10.3	20	5	0.5	45	<input type="checkbox"/>		<input type="checkbox"/>	<input type="checkbox"/>	<input type="checkbox"/>	<input type="checkbox"/>											
	10.2	10.5					<input type="checkbox"/>	<input type="checkbox"/>	<input type="checkbox"/>	<input type="checkbox"/>	<input type="checkbox"/>												
	12	12.3					<input type="checkbox"/>	<input type="checkbox"/>	<input type="checkbox"/>	<input type="checkbox"/>	<input type="checkbox"/>												
	12	12.3					<input type="checkbox"/>	<input type="checkbox"/>	<input type="checkbox"/>	<input type="checkbox"/>	<input type="checkbox"/>												

Warmarbeitsstahl

Härte :

Schaft > 950 HV 0.3  
Kopf 45 + 5 HRC  
Kern -1500 N/mm<sup>2</sup>

## R241/DxBxL

gehärtet  
DIN 16756

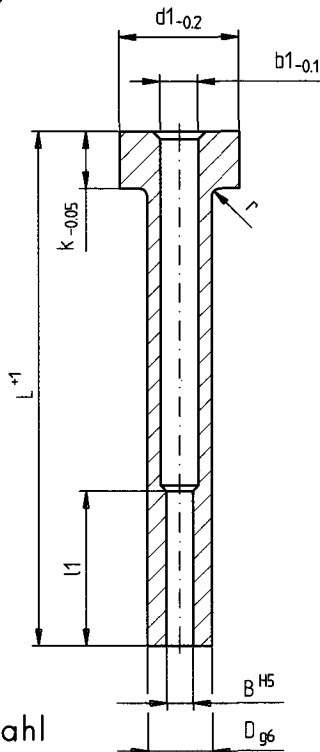

D	B	b1	d1	k	r	L1	L															
							60	75	100	125	150	175	200	225	250	275						
3	15	19	6	3	0.3	35	<input type="checkbox"/>	<input type="checkbox"/>	<input type="checkbox"/>	<input type="checkbox"/>												
	16						<input type="checkbox"/>	<input type="checkbox"/>	<input type="checkbox"/>	<input type="checkbox"/>	<input type="checkbox"/>											
4	2	2.4	8	5	0.5	35	<input type="checkbox"/>	<input type="checkbox"/>	<input type="checkbox"/>	<input type="checkbox"/>	<input type="checkbox"/>	<input type="checkbox"/>										
	2.2						<input type="checkbox"/>	<input type="checkbox"/>	<input type="checkbox"/>	<input type="checkbox"/>	<input type="checkbox"/>											
5	2.5	3	10	7	0.8	45	<input type="checkbox"/>	<input type="checkbox"/>	<input type="checkbox"/>	<input type="checkbox"/>	<input type="checkbox"/>	<input type="checkbox"/>										
	2.7						<input type="checkbox"/>	<input type="checkbox"/>	<input type="checkbox"/>	<input type="checkbox"/>	<input type="checkbox"/>											
	3	3.3					<input type="checkbox"/>	<input type="checkbox"/>	<input type="checkbox"/>	<input type="checkbox"/>	<input type="checkbox"/>											
	3.2	3.5					<input type="checkbox"/>	<input type="checkbox"/>	<input type="checkbox"/>	<input type="checkbox"/>	<input type="checkbox"/>											
6	3.5	4	12	5	0.5	45	<input type="checkbox"/>	<input type="checkbox"/>	<input type="checkbox"/>	<input type="checkbox"/>	<input type="checkbox"/>	<input type="checkbox"/>										
	3.7						<input type="checkbox"/>	<input type="checkbox"/>	<input type="checkbox"/>	<input type="checkbox"/>	<input type="checkbox"/>											
	4	4.3					<input type="checkbox"/>	<input type="checkbox"/>	<input type="checkbox"/>	<input type="checkbox"/>	<input type="checkbox"/>											
	4.2	5					<input type="checkbox"/>	<input type="checkbox"/>	<input type="checkbox"/>	<input type="checkbox"/>	<input type="checkbox"/>											
8	5	5.3	14	7	0.8	45	<input type="checkbox"/>	<input type="checkbox"/>	<input type="checkbox"/>	<input type="checkbox"/>	<input type="checkbox"/>	<input type="checkbox"/>										
	5.2	5.5					<input type="checkbox"/>	<input type="checkbox"/>	<input type="checkbox"/>	<input type="checkbox"/>	<input type="checkbox"/>											
	6	6.3					<input type="checkbox"/>	<input type="checkbox"/>	<input type="checkbox"/>	<input type="checkbox"/>	<input type="checkbox"/>											
	6.2	6.5					<input type="checkbox"/>	<input type="checkbox"/>	<input type="checkbox"/>	<input type="checkbox"/>	<input type="checkbox"/>											
10	8	8.3	16	5	0.5	45	<input type="checkbox"/>	<input type="checkbox"/>	<input type="checkbox"/>	<input type="checkbox"/>	<input type="checkbox"/>	<input type="checkbox"/>										
	8.2	8.5					<input type="checkbox"/>	<input type="checkbox"/>	<input type="checkbox"/>	<input type="checkbox"/>	<input type="checkbox"/>											
	10	10.3					<input type="checkbox"/>	<input type="checkbox"/>	<input type="checkbox"/>	<input type="checkbox"/>	<input type="checkbox"/>											
	10.5	11					<input type="checkbox"/>	<input type="checkbox"/>	<input type="checkbox"/>	<input type="checkbox"/>	<input type="checkbox"/>											
12	12	12.3	20	7	0.8	45	<input type="checkbox"/>	<input type="checkbox"/>	<input type="checkbox"/>	<input type="checkbox"/>	<input type="checkbox"/>	<input type="checkbox"/>										
	12.5	13					<input type="checkbox"/>	<input type="checkbox"/>	<input type="checkbox"/>	<input type="checkbox"/>	<input type="checkbox"/>											
	12	12.3					<input type="checkbox"/>	<input type="checkbox"/>	<input type="checkbox"/>	<input type="checkbox"/>	<input type="checkbox"/>											
	12	12.3					<input type="checkbox"/>	<input type="checkbox"/>	<input type="checkbox"/>	<input type="checkbox"/>	<input type="checkbox"/>											

legierter  
Werkzeugstahl

Härte :

Schaft 62 ± 2 HRC  
Kopf 45 ± 5 HRC

## R25/AxBxL

gasnitriert  
DIN 1530-F

AxB	d1	d2	k	r	L																		
					l1	60	80	100	125	160	200	250	315	400									
35x1	4	8	3	0.3																			
38x0.8	4.2																						
38x1																							
38x12																							
45x1	5	10																					
45x12																							
45x15																							
55x1	6	12	5	0.5																			
55x12																							
55x15																							
55x2																							
75x12																							
75x15	8	14																					
75x2																							
95x15																							
95x2	10	16																					
115x2	12	20	7	0.8																			
115x2.5																							
155x2																							
155x2.5	16	22																					

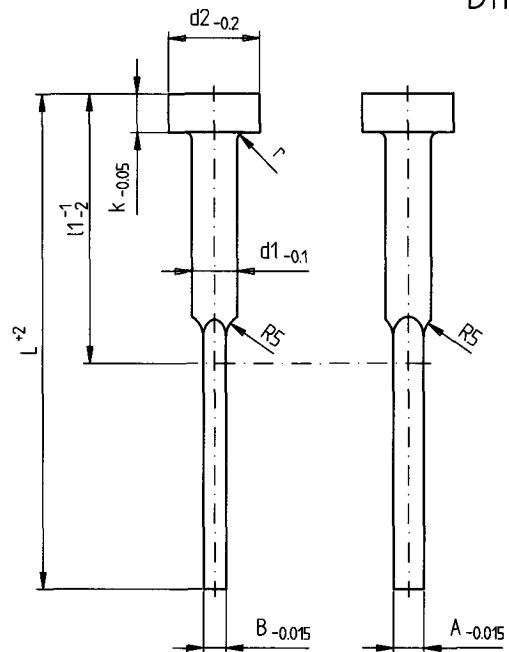

Warmarbeitsstahl

Härte :

Schaft > 950 HV 0.3  
Kopf 45 + 5 HRC  
Kern -1500 N/mm<sup>2</sup>

Stand 05/94

## R251/AxBxL

gehärtet  
DIN 1530-F

AxB	d1	d2	k	r	L																		
					l1	60	80	100	125	160	200	250	315										
35x1	4	8	3	0.3																			
38x0.8	4.2																						
38x1																							
38x12																							
45x1	5	10																					
45x12																							
45x15																							
55x1	6	12	5	0.5																			
55x12																							
55x15																							
55x2																							
75x12																							
75x15	8	14																					
75x2																							
95x15																							
95x2	10	16																					
115x2	12	20	7	0.8																			
115x2.5																							

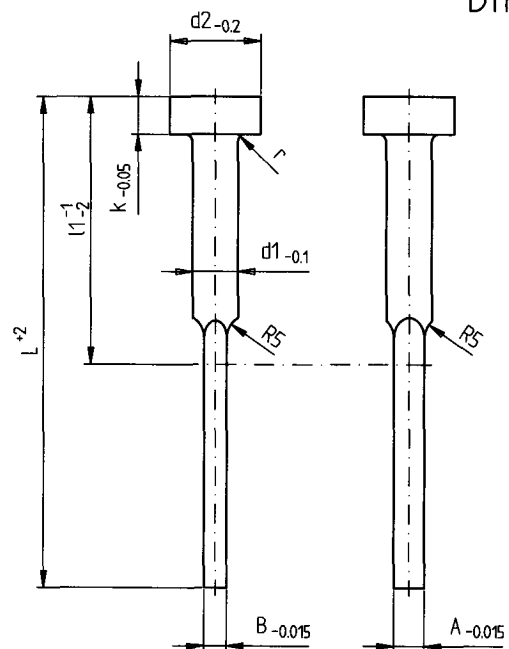

legierter  
Werkzeugstahl

Härte :

Schaft 62 ± 2 HRC  
Kopf 45 ± 5 HRC

## R27/DxL

gehärtet  
DIN 9861-DA

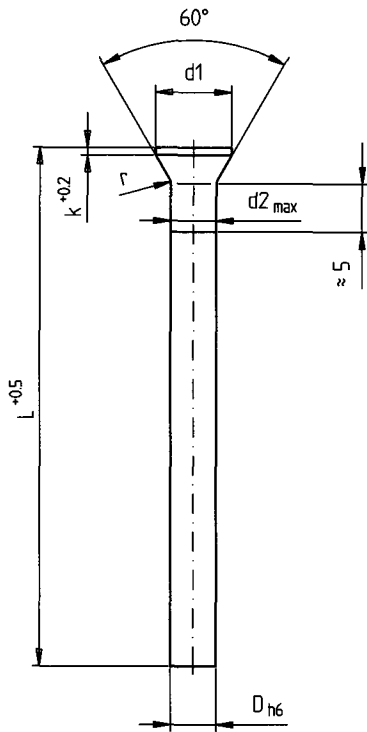

Durchmesser D gestuft um	D	d1	d2	k	L	70				
	0.05	0.5	0.9	D + 0.02	0.2		<input type="checkbox"/>			
0.55		1.0	<input type="checkbox"/>							
0.6		1.1	<input type="checkbox"/>							
0.65		1.2	<input type="checkbox"/>							
0.7 und 0.75		1.3	<input type="checkbox"/>							
0.8 und 0.85		1.4	0.4				<input type="checkbox"/>			
0.9 und 0.95		1.6					<input type="checkbox"/>			
0.1		1.0 und 1.1	1.8				D + 0.03	0.5		<input type="checkbox"/>
		1.2 und 1.3	2.0							<input type="checkbox"/>
		1.4 und 1.5	2.2							<input type="checkbox"/>
	1.6 und 1.7	2.5	<input type="checkbox"/>							
	1.8 und 1.9	2.8	<input type="checkbox"/>							
	2.0	3.0	<input type="checkbox"/>							
	2.1 und 2.2	3.2	<input type="checkbox"/>							
	von 2.3 bis 2.5	3.5	<input type="checkbox"/>							
	von 2.6 bis 2.9	4.0	<input type="checkbox"/>							
	von 3.0 bis 3.4	4.5	<input type="checkbox"/>							
	von 3.5 bis 3.9	5.0	<input type="checkbox"/>							
	von 4.0 bis 4.4	5.5	<input type="checkbox"/>							
	von 4.5 bis 4.9	6.0	<input type="checkbox"/>							
	von 5.0 bis 5.4	6.5	<input type="checkbox"/>							
	von 5.5 bis 5.9	7.0	<input type="checkbox"/>							
von 6.0 bis 6.4	8.0	D + 0.04	1.0		<input type="checkbox"/>					
6.5 und 7.0	9.0				<input type="checkbox"/>					
7.5 und 8.0	10.0				<input type="checkbox"/>					
8.5 und 9.0	11.0				<input type="checkbox"/>					
9.5 und 10.0	12.0				<input type="checkbox"/>					
10.5 und 11.0	13.0				<input type="checkbox"/>					
11.5 und 12.0	14.0				<input type="checkbox"/>					
12.5 und 13.0	15.0				<input type="checkbox"/>					
13.5 und 14.0	16.0				15	<input type="checkbox"/>				
14.5 und 15.0	17.0					<input type="checkbox"/>				
15.5 und 16.0	18.0	<input type="checkbox"/>								

legierter  
Werkzeugstahl

Härte :

Schaft  $62 \pm 2$  HRC  
Kopf  $45 \pm 5$  HRC

a <sup>1)</sup>	2.1	2.4	3	4	4.5	5.3	6	7.5
b <sup>2)</sup>	14	16	18	22	26	30	38	46
b <sup>3)</sup>	-	-	24	28	32	36	44	52
b <sup>4)</sup>	-	-	-	-	45	49	57	65
d1	7	8.5	10	13	16	18	24	30
k	4	5	6	8	10	12	16	20
s	3	4	5	6	8	10	14	17

<b>D</b>	M4	M5	M6	M8	M10	M12	M16	M20
----------	----	----	----	----	-----	-----	-----	-----

<b>L</b>								
8	<input type="checkbox"/>							
10	<input type="checkbox"/>	<input type="checkbox"/>	<input type="checkbox"/>					
12	<input type="checkbox"/>	<input type="checkbox"/>	<input type="checkbox"/>	<input type="checkbox"/>				
16	<input type="checkbox"/>	<input type="checkbox"/>	<input type="checkbox"/>	<input type="checkbox"/>	<input type="checkbox"/>			
18	<input type="checkbox"/>	<input type="checkbox"/>	<input type="checkbox"/>	<input type="checkbox"/>	<input type="checkbox"/>			
20	<input type="checkbox"/>	<input type="checkbox"/>	<input type="checkbox"/>	<input type="checkbox"/>	<input type="checkbox"/>	<input type="checkbox"/>		
25	<input type="checkbox"/>	<input type="checkbox"/>	<input type="checkbox"/>	<input type="checkbox"/>	<input type="checkbox"/>	<input type="checkbox"/>	<input type="checkbox"/>	
30	<input type="checkbox"/>	<input type="checkbox"/>	<input type="checkbox"/>	<input type="checkbox"/>	<input type="checkbox"/>	<input type="checkbox"/>	<input type="checkbox"/>	<input type="checkbox"/>
35	<input type="checkbox"/>	<input type="checkbox"/>	<input type="checkbox"/>	<input type="checkbox"/>	<input type="checkbox"/>	<input type="checkbox"/>	<input type="checkbox"/>	<input type="checkbox"/>
40	<input type="checkbox"/>	<input type="checkbox"/>	<input type="checkbox"/>	<input type="checkbox"/>	<input type="checkbox"/>	<input type="checkbox"/>	<input type="checkbox"/>	<input type="checkbox"/>
45			<input type="checkbox"/>	<input type="checkbox"/>	<input type="checkbox"/>	<input type="checkbox"/>	<input type="checkbox"/>	<input type="checkbox"/>
50			<input type="checkbox"/>	<input type="checkbox"/>	<input type="checkbox"/>	<input type="checkbox"/>	<input type="checkbox"/>	<input type="checkbox"/>
55			<input type="checkbox"/>	<input type="checkbox"/>	<input type="checkbox"/>	<input type="checkbox"/>	<input type="checkbox"/>	<input type="checkbox"/>
60			<input type="checkbox"/>	<input type="checkbox"/>	<input type="checkbox"/>	<input type="checkbox"/>	<input type="checkbox"/>	<input type="checkbox"/>
65			<input type="checkbox"/>	<input type="checkbox"/>	<input type="checkbox"/>	<input type="checkbox"/>	<input type="checkbox"/>	<input type="checkbox"/>
70			<input type="checkbox"/>	<input type="checkbox"/>	<input type="checkbox"/>	<input type="checkbox"/>	<input type="checkbox"/>	<input type="checkbox"/>
75			<input type="checkbox"/>	<input type="checkbox"/>	<input type="checkbox"/>	<input type="checkbox"/>	<input type="checkbox"/>	<input type="checkbox"/>
80			<input type="checkbox"/>	<input type="checkbox"/>	<input type="checkbox"/>	<input type="checkbox"/>	<input type="checkbox"/>	<input type="checkbox"/>
90			<input type="checkbox"/>	<input type="checkbox"/>	<input type="checkbox"/>	<input type="checkbox"/>	<input type="checkbox"/>	<input type="checkbox"/>
100			<input type="checkbox"/>	<input type="checkbox"/>	<input type="checkbox"/>	<input type="checkbox"/>	<input type="checkbox"/>	<input type="checkbox"/>
110			<input type="checkbox"/>	<input type="checkbox"/>	<input type="checkbox"/>	<input type="checkbox"/>	<input type="checkbox"/>	<input type="checkbox"/>
120			<input type="checkbox"/>	<input type="checkbox"/>	<input type="checkbox"/>	<input type="checkbox"/>	<input type="checkbox"/>	<input type="checkbox"/>
130				<input type="checkbox"/>	<input type="checkbox"/>	<input type="checkbox"/>	<input type="checkbox"/>	<input type="checkbox"/>
140			<input type="checkbox"/>	<input type="checkbox"/>	<input type="checkbox"/>	<input type="checkbox"/>	<input type="checkbox"/>	<input type="checkbox"/>
150			<input type="checkbox"/>	<input type="checkbox"/>	<input type="checkbox"/>	<input type="checkbox"/>	<input type="checkbox"/>	<input type="checkbox"/>
160			<input type="checkbox"/>	<input type="checkbox"/>	<input type="checkbox"/>	<input type="checkbox"/>	<input type="checkbox"/>	<input type="checkbox"/>
170				<input type="checkbox"/>	<input type="checkbox"/>	<input type="checkbox"/>	<input type="checkbox"/>	<input type="checkbox"/>
180				<input type="checkbox"/>	<input type="checkbox"/>	<input type="checkbox"/>	<input type="checkbox"/>	<input type="checkbox"/>
190					<input type="checkbox"/>	<input type="checkbox"/>	<input type="checkbox"/>	<input type="checkbox"/>
200				<input type="checkbox"/>	<input type="checkbox"/>	<input type="checkbox"/>	<input type="checkbox"/>	<input type="checkbox"/>
210						<input type="checkbox"/>	<input type="checkbox"/>	<input type="checkbox"/>
220					<input type="checkbox"/>	<input type="checkbox"/>	<input type="checkbox"/>	<input type="checkbox"/>
240					<input type="checkbox"/>	<input type="checkbox"/>	<input type="checkbox"/>	<input type="checkbox"/>
260					<input type="checkbox"/>	<input type="checkbox"/>	<input type="checkbox"/>	<input type="checkbox"/>
270						<input type="checkbox"/>	<input type="checkbox"/>	<input type="checkbox"/>
280							<input type="checkbox"/>	<input type="checkbox"/>
300							<input type="checkbox"/>	<input type="checkbox"/>
320							<input type="checkbox"/>	<input type="checkbox"/>
340							<input type="checkbox"/>	<input type="checkbox"/>

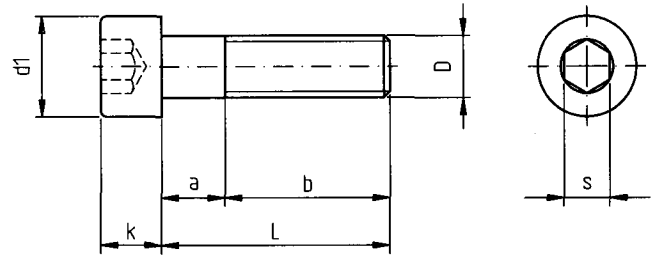

- <sup>1)</sup> für Längen oberhalb der Stufenlinie ist  $b-l-a$
- <sup>2)</sup> für Längen bis 120 mm
- <sup>3)</sup> für Längen über 120 mm bis 200 mm
- <sup>4)</sup> für Längen über 200 mm

Stand 05.94

780 - 980 N/mm<sup>2</sup> (80 - 100 kp/mm<sup>2</sup>)

D	l	d2	d3	d4	h	k	max. kg	
M10	17	25	45	25	45	10	230	170
M12	20.5	30	54	30	53	12	340	240
M16	27	35	63	35	62	14	700	500
M20	30	40	72	40	71	16	1200	830
M24	36	50	90	50	90	20	1800	1270
M30	45	65	108	60	109	24	3600	2600

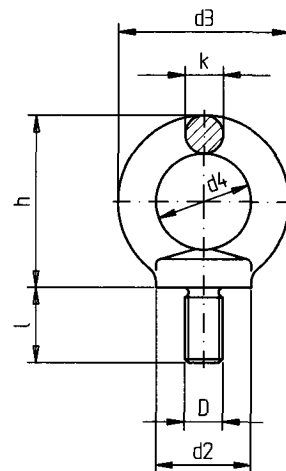

## R56/Da/S/Di

DIN 2093

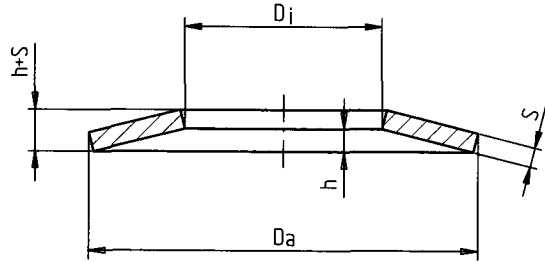

18159

$F[N] \times 0.102 = F[kp]$   
 $f$  : Federweg des Einzeltellers

Da	S	Di	h	h + S	f = 0.25 x h		f = 0.5 x h		f = 0.75 x h		
					f	F [N]	f	F [N]	f	F [N]	
8	0.3	4.2	0.25	0.55	0.063	52	0.125	89	0.188	118	
	0.4		0.2	0.6	0.05	78	0.1	147	0.15	210	
10	0.4	5.2	0.3	0.7	0.075	83	0.15	148	0.225	199	
	0.5		0.25	0.75	0.062	116	0.125	218	0.187	310	
12	0.5	5.2	0.4	0.9	0.1	143	0.2	250	0.3	333	
12.5	0.5	6.2	0.35	0.85	0.087	115	0.175	205	0.262	280	
	0.7		0.3	1.0	0.075	229	0.15	436	0.225	628	
14	0.5	7.2	0.4	0.9	0.1	115	0.2	200	0.3	266	
	0.8		0.3	1.1	0.075	271	0.15	521	0.225	759	
15	0.5	6.2	0.5	1.0	0.125	131	0.25	219	0.375	276	
16	0.6	8.2	0.45	1.05	0.112	164	0.225	289	0.337	390	
	0.9		0.35	1.25	0.087	345	0.175	664	0.262	964	
18	0.4	6.2	0.6	1.0	0.15	80	0.3	120	0.45	132	
			0.5	0.6	1.1	0.15	124	0.3	196	0.45	233
	0.6	6.2	0.6	1.2	0.15	182	0.3	302	0.45	382	
			0.7	0.55	1.25	0.137	225	0.275	394	0.412	527
	0.7	8.2	0.55	1.25	0.137	242	0.275	425	0.412	568	
	0.7	9.2	0.5	1.2	0.125	223	0.25	397	0.375	540	
20	0.8	10.2	0.4	1.4	0.1	430	0.2	823	0.3	1195	
			0.55	1.35	0.137	289	0.275	521	0.412	712	
			0.45	1.55	0.112	522	0.225	1000	0.337	1448	
23	0.9	10.2	0.75	1.65	0.187	441	0.375	764	0.562	1007	
			0.9	1.6	0.225	316	0.45	491	0.675	571	
25	0.7	12.2	0.7	1.6	0.175	349	0.35	614	0.525	821	
			15	0.55	2.05	0.137	990	0.275	1911	0.412	2787
			0.8	10.2	0.8	2.05	0.2	701	0.4	1275	0.6
28	0.8	14.2	10	1.8	0.25	414	0.5	648	0.75	763	
			0.8	1.8	0.2	454	0.4	793	0.6	1055	
			15	0.65	2.15	0.162	984	0.325	1876	0.487	2706
			0.8	16.3	1.1	1.9	0.275	403	0.55	615	0.825
31.5	1.25	16.3	0.9	2.15	0.225	753	0.45	1342	0.675	1822	
			1.75	0.7	2.45	0.175	1325	0.35	2542	0.525	3687
			0.9	18.3	1.2	2.1	0.3	476	0.6	732	0.9
35.5	1.25	18.3	10	2.25	0.25	670	0.5	1215	0.75	1618	
			2.0	0.8	2.8	0.2	1776	0.4	3406	0.6	4940
			10	20.4	1.3	2.3	0.325	539	0.65	834	0.975
40	1.5	20.4	1.5	2.65	0.287	1057	0.575	1861	0.862	2497	
			2.25	0.9	3.15	0.225	2225	0.45	4268	0.675	6191
			1.25	22.4	1.65	2.9	0.412	1057	0.825	1629	1.238
45	1.75	22.4	1.3	3.05	0.325	1452	0.65	2572	0.975	3473	
			2.5	1.0	3.5	0.25	2641	0.5	5067	0.75	7349
			1.25	25.4	1.6	2.85	0.4	813	0.8	1266	1.2
50	2.0	25.4	1.4	3.4	0.35	1856	0.7	3325	1.05	4535	
			3.0	1.1	4.1	0.275	4053	0.55	7823	0.825	11409
			2.0	28.5	1.6	3.6	0.4	1819	0.8	3176	1.2
56	3.0	28.5	1.3	4.3	0.325	3946	0.65	7519	0.975	10850	
			1.8	31	2.4	4.2	0.6	2351	1.2	3617	1.8
63	3.5	31	1.4	4.9	0.35	5142	0.7	9869	1.05	14313	
			2.5	36	2.0	4.5	0.5	2757	1.0	4814	1.5

Stand 05/94

## R62/BxLxS

Druckfestigkeit = 600 N/mm<sup>2</sup>  
Wärmeleitzahl = 0.21 W/mK

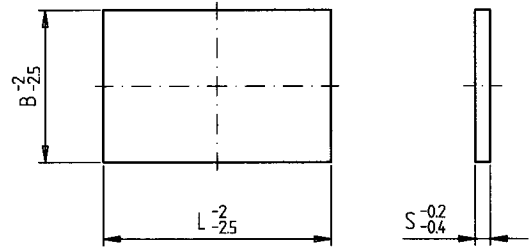

B	L \ S	3	5	7	8.5	
96	96	<input type="checkbox"/>	<input type="checkbox"/>			
	125	<input type="checkbox"/>	<input type="checkbox"/>			
	156	156	<input type="checkbox"/>	<input type="checkbox"/>		
		196	<input type="checkbox"/>	<input type="checkbox"/>		
		246	<input type="checkbox"/>	<input type="checkbox"/>		
190	296		<input type="checkbox"/>			
	396		<input type="checkbox"/>			
	190	246	<input type="checkbox"/>	<input type="checkbox"/>		
		296		<input type="checkbox"/>		
		196	<input type="checkbox"/>	<input type="checkbox"/>		
196	246	<input type="checkbox"/>	<input type="checkbox"/>			
	296		<input type="checkbox"/>	<input type="checkbox"/>		
	346		<input type="checkbox"/>	<input type="checkbox"/>		
	396			<input type="checkbox"/>		
	446			<input type="checkbox"/>		
206	156	<input type="checkbox"/>	<input type="checkbox"/>			
	196	<input type="checkbox"/>	<input type="checkbox"/>			
218	246		<input type="checkbox"/>			
	296		<input type="checkbox"/>			
	396			<input type="checkbox"/>		
246	246		<input type="checkbox"/>	<input type="checkbox"/>		
	296		<input type="checkbox"/>	<input type="checkbox"/>		
	346		<input type="checkbox"/>	<input type="checkbox"/>		
	396		<input type="checkbox"/>	<input type="checkbox"/>		

B	L \ S	3	5	7	8.5
246	446			<input type="checkbox"/>	
	496				<input type="checkbox"/>
254	246		<input type="checkbox"/>	<input type="checkbox"/>	
	276		<input type="checkbox"/>		
296	296			<input type="checkbox"/>	
	346			<input type="checkbox"/>	<input type="checkbox"/>
	396			<input type="checkbox"/>	<input type="checkbox"/>
	446			<input type="checkbox"/>	
	496			<input type="checkbox"/>	<input type="checkbox"/>
346	546				<input type="checkbox"/>
	596				<input type="checkbox"/>
	696				<input type="checkbox"/>
	346	346		<input type="checkbox"/>	<input type="checkbox"/>
	396	396		<input type="checkbox"/>	<input type="checkbox"/>
396	446			<input type="checkbox"/>	<input type="checkbox"/>
	496			<input type="checkbox"/>	<input type="checkbox"/>
	546				<input type="checkbox"/>
	596				<input type="checkbox"/>
	696				<input type="checkbox"/>

B	L \ S	3	5	7	8.5
396	546			<input type="checkbox"/>	<input type="checkbox"/>
	596				<input type="checkbox"/>
	696				<input type="checkbox"/>
	796				<input type="checkbox"/>
	896				<input type="checkbox"/>
446	446				<input type="checkbox"/>
	496				<input type="checkbox"/>
	546				<input type="checkbox"/>
	596				<input type="checkbox"/>
	696				<input type="checkbox"/>
496	796				<input type="checkbox"/>
	896				<input type="checkbox"/>
	496	496			<input type="checkbox"/>
	546			<input type="checkbox"/>	<input type="checkbox"/>
	596			<input type="checkbox"/>	<input type="checkbox"/>
546	696				<input type="checkbox"/>
	796				<input type="checkbox"/>
	896				<input type="checkbox"/>
	996				<input type="checkbox"/>
	546	546			<input type="checkbox"/>
596	596				<input type="checkbox"/>
	646				<input type="checkbox"/>
	696				<input type="checkbox"/>
	796				<input type="checkbox"/>

B	L \ S	3	5	7	8.5
546	896				<input type="checkbox"/>
	996				<input type="checkbox"/>
596	596				<input type="checkbox"/>
	696				<input type="checkbox"/>
	796				<input type="checkbox"/>
	896				<input type="checkbox"/>
	996				<input type="checkbox"/>
646	596				<input type="checkbox"/>
	696				<input type="checkbox"/>
	796				<input type="checkbox"/>
	896				<input type="checkbox"/>
	996				<input type="checkbox"/>
696	696				<input type="checkbox"/>
	796				<input type="checkbox"/>
	896				<input type="checkbox"/>
	996				<input type="checkbox"/>
	696	696			<input type="checkbox"/>
796	796				<input type="checkbox"/>
	896				<input type="checkbox"/>
	996				<input type="checkbox"/>
	796	796			<input type="checkbox"/>
	896	896			<input type="checkbox"/>
896	896				<input type="checkbox"/>
	996				<input type="checkbox"/>

Stand: 05/94

## R621/BxLxS

Druckfestigkeit = 600 N/mm<sup>2</sup>  
Wärmeleitzahl = 0.21 W/mK

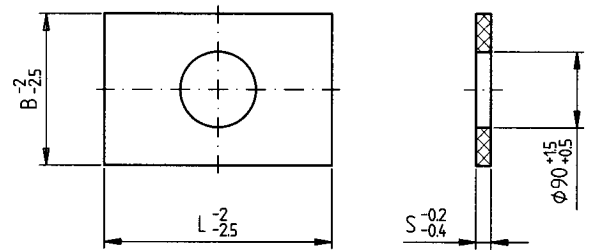

B	L \ S	3	5	7	8.5	
125	125	<input type="checkbox"/>	<input type="checkbox"/>			
	156	156	<input type="checkbox"/>	<input type="checkbox"/>		
		196	<input type="checkbox"/>	<input type="checkbox"/>		
		246	<input type="checkbox"/>	<input type="checkbox"/>		
		296		<input type="checkbox"/>		
190	396		<input type="checkbox"/>			
	246	<input type="checkbox"/>	<input type="checkbox"/>			
	296		<input type="checkbox"/>			
	196	196	<input type="checkbox"/>	<input type="checkbox"/>		
		246	<input type="checkbox"/>	<input type="checkbox"/>		
296			<input type="checkbox"/>	<input type="checkbox"/>		
196	346		<input type="checkbox"/>	<input type="checkbox"/>		
	396			<input type="checkbox"/>		
	446			<input type="checkbox"/>		
	206	156	<input type="checkbox"/>	<input type="checkbox"/>		
		196	<input type="checkbox"/>	<input type="checkbox"/>		
218	246		<input type="checkbox"/>			

B	L \ S	3	5	7	8.5
218	296		<input type="checkbox"/>		
	396			<input type="checkbox"/>	
246	246		<input type="checkbox"/>	<input type="checkbox"/>	
	296		<input type="checkbox"/>	<input type="checkbox"/>	
	346		<input type="checkbox"/>	<input type="checkbox"/>	
	396		<input type="checkbox"/>	<input type="checkbox"/>	
	446			<input type="checkbox"/>	
254	246		<input type="checkbox"/>	<input type="checkbox"/>	
	276		<input type="checkbox"/>		
296	296			<input type="checkbox"/>	
	346			<input type="checkbox"/>	<input type="checkbox"/>
	396			<input type="checkbox"/>	<input type="checkbox"/>
	446				<input type="checkbox"/>
	496				<input type="checkbox"/>

B	L \ S	3	5	7	8.5
296	596				<input type="checkbox"/>
	696				<input type="checkbox"/>
346	346			<input type="checkbox"/>	<input type="checkbox"/>
	396			<input type="checkbox"/>	<input type="checkbox"/>
	446			<input type="checkbox"/>	<input type="checkbox"/>
	496			<input type="checkbox"/>	<input type="checkbox"/>
	546				<input type="checkbox"/>
396	596				<input type="checkbox"/>
	696				<input type="checkbox"/>
	396	396			<input type="checkbox"/>
	446			<input type="checkbox"/>	<input type="checkbox"/>
	496			<input type="checkbox"/>	<input type="checkbox"/>
446	546			<input type="checkbox"/>	<input type="checkbox"/>
	596				<input type="checkbox"/>
	696				<input type="checkbox"/>
	446	446			<input type="checkbox"/>
	496				<input type="checkbox"/>

B	L \ S	3	5	7	8.5
446	546				<input type="checkbox"/>
	596				<input type="checkbox"/>
496	696				<input type="checkbox"/>
	496				<input type="checkbox"/>
	546			<input type="checkbox"/>	
	596				<input type="checkbox"/>
	696				<input type="checkbox"/>
546	546				<input type="checkbox"/>
	596				<input type="checkbox"/>
	646				<input type="checkbox"/>
	696				<input type="checkbox"/>
	596	596			<input type="checkbox"/>
596	596				<input type="checkbox"/>
	696				<input type="checkbox"/>
	696				<input type="checkbox"/>
646	596				<input type="checkbox"/>
	696				<input type="checkbox"/>

D	d1	Außen- $\phi$ <sup>1)</sup>		b <sup>2)</sup>	t <sup>2)</sup>	s <sup>2)</sup>	r	z
		von	bis					
6.0	15	8.7	9.5	19	1.1	2.0	0.3	10
7.5		10.2	11.1					
8.0	2.0	11.6	12.7	2.6	1.5	2.7		12
10.0	2.5	14.6	15.9	3.2	1.9	3.4		14
11.0		15.5	17.0					
	3.0	16.5	18.0	3.9	2.3	4.1		16
12.0	2.0	15.5	17.0	2.6	1.5	2.7		12
13.3	2.4	17.6	19.2	3.1	1.8	3.3		14
15.3		19.5	21.3					
17.5		21.6	23.6					
19.3		23.4	25.6					
21.3		25.3	27.7					
23.3		27.3	29.8					
25.3		29.2	31.9					
27.3		31.3	34.0					
28.0	3.0	33.0	36.0	3.9	2.3	4.1		16
30.2		35.1	38.4					
32.0	1.5	34.0	37.1	1.9	1.1	2.0		10
	2.0	34.9	38.2	2.6	1.5	2.7		12
	2.5	35.9	39.2	3.2	1.9	3.4		14
34.2	3.0	39.0	42.6	3.9	2.3	4.1		16
35.0	1.5	36.9	40.3	1.9	1.1	2.0		10
36.0	3.0	40.7	44.5	3.9	2.3	4.1		16
39.0		43.7	47.7					
40.0	2.0	42.7	46.6	2.6	1.5	2.7		12
44.0	3.0	48.5	53.0	3.9	2.3	4.1		16
49.0		53.4	58.3					
54.0		58.2	63.3					
59.0		63.1	68.9					
63.0		66.9	73.1					
68.0	4.0	73.7	80.6	5.2	3.2	5.5	0.5	2.0
73.0	3.5	77.6	84.8	4.5	2.7	4.8		1.8
84.0	3.0	87.3	95.4	3.9	2.3	4.1	0.3	1.6
92.0		95.1	103.9					
100.0		102.8	112.4					
	4.0	104.8	114.5	5.2	3.2	5.5	0.5	2.0
105.0		109.6	119.8					
120.0	2.0	120.3	131.4	2.6	1.5	2.7	0.3	1.2
130.0	5.0	135.8	148.4	6.5	4.0	6.9	0.5	2.5
140.0	4.0	143.6	156.9	5.2	3.2	5.5		2.0
150.0		153.3	167.5					
185.0		187.2	204.6					

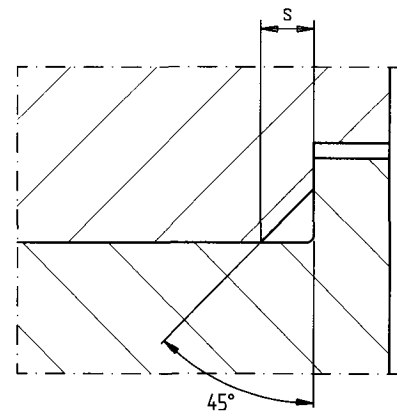
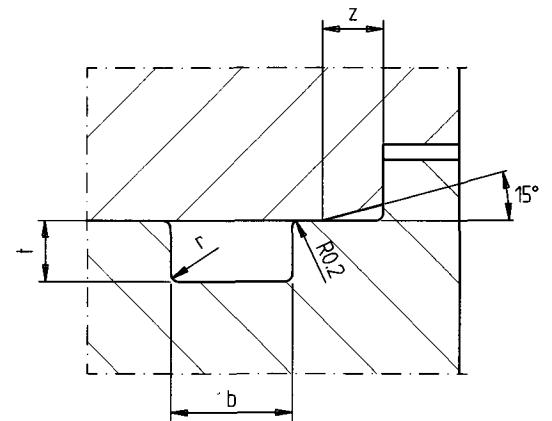
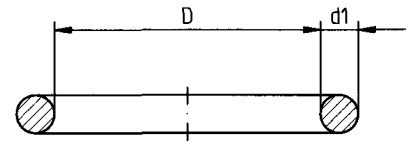

<sup>1)</sup> zul. Stauchung (3%)  
und Dehnung (6%)  
<sup>2)</sup> für statische Abdichtung

## R46/d1/D

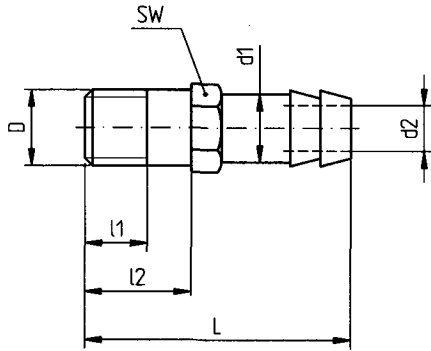

D	d1	d2	L	l1	l2	SW
M10×1	9	6	35	7	14	11
R1/8"						
M12×15	13	8	47	9	16	15
M14×15		9				
R1/4"						

Ms

## R461/d1/D

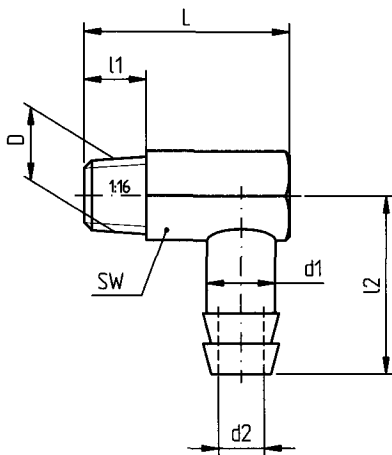

D	d1	d2	L	l1	l2	SW
M8×0.75	9	5	27	9	23	11
M10×1		6				
R1/8"						
M14×15	13	9	34		32.5	15
R1/4"						

Ms

## R462/D×L

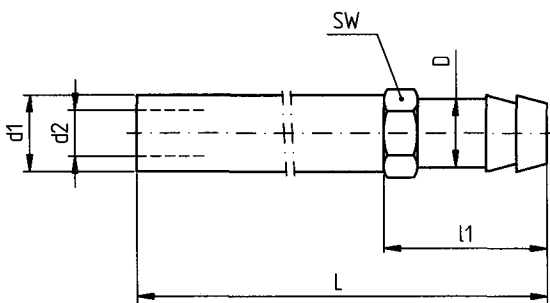

D	d1	d2	SW	l1	L					
					120	150	240	300	360	450
9	10	6	11	25	<input type="checkbox"/>	<input type="checkbox"/>	<input type="checkbox"/>	<input type="checkbox"/>	<input type="checkbox"/>	<input type="checkbox"/>
13	14	9	15	35	<input type="checkbox"/>	<input type="checkbox"/>	<input type="checkbox"/>	<input type="checkbox"/>	<input type="checkbox"/>	<input type="checkbox"/>

Ms

## R48/D

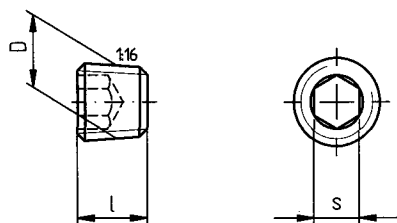

D	l	s
M8×0.75	8	4
M10×1		5
M12×15	10	6
M14×15		7
R1/8"	8	5
R1/4"	10	7
R3/8"		8
R1/2"		10

Ms

## R49/D

D	d1	d2	L	l1	bar	°C
9	17	6	47	17	15	200/Viton
13	22	9	61	25	10	

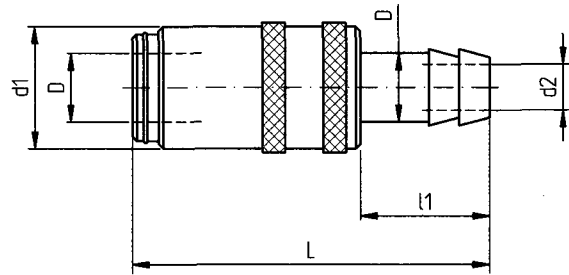

Ms

## R491/D

D	d1	d2	L	l1	bar	°C
9	17	6	41	17	15	200/Viton
13	22	9	51	25	10	

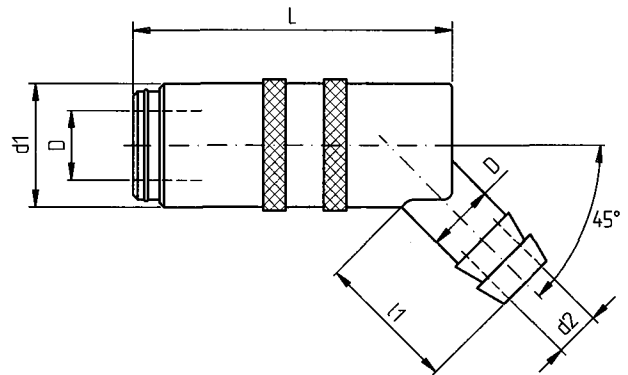

Ms

## R492/D

D	d1	d2	L	l1	bar	°C
9	17	6	41	19	15	200/Viton
13	22	9	51	28	10	

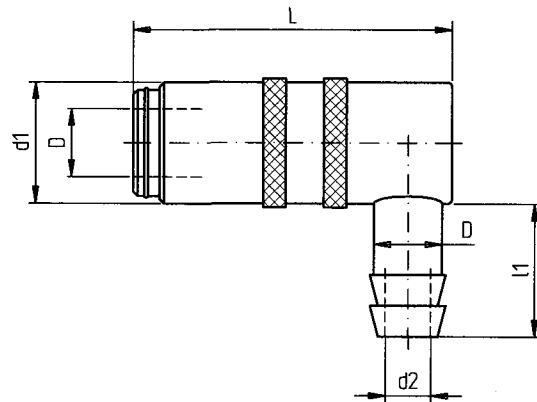

Ms

## R50/D

D	d1	d2	L	l1	bar	°C
9	17	6	47	17	15	200/Viton
13	22	9	61	25	10	

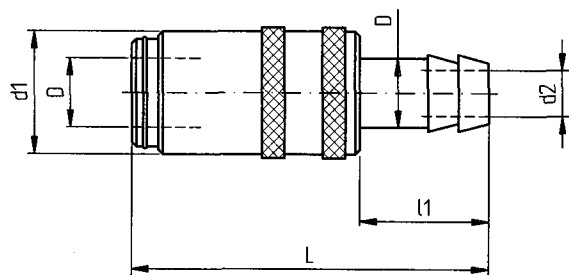

Ms

## R501/D

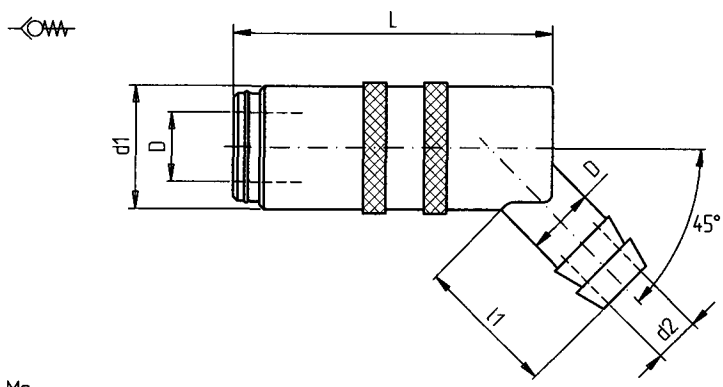

D	d1	d2	L	l1	bar	°C
9	17	6	41	17	15	200/Viton
13	22	9	51	25	10	

Ms

## R502/D

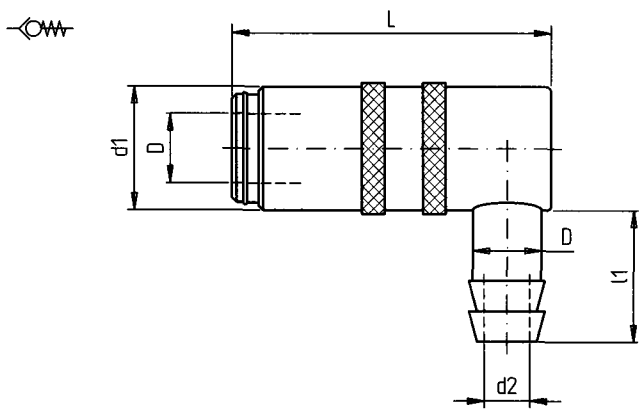

D	d1	d2	L	l1	bar	°C
9	17	6	41	19	15	200/Viton
13	22	9	51	28	10	

Ms

## R51/d1/D

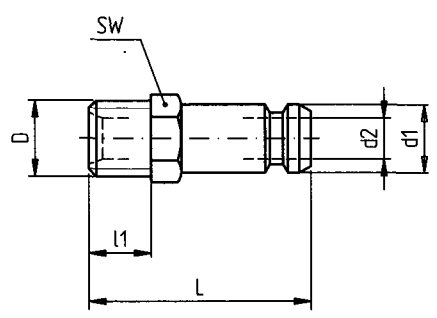

D	d1	d2	L	l1	SW
M8×0.75	9	4.5	24	7	11
M10×1		6			
R1/8"					
M14×1.5			26	9	15
	13	9			
R1/4"		6			
	13	9			
M16×1.5					17
R3/8"					

Ms

## R511/d1/D

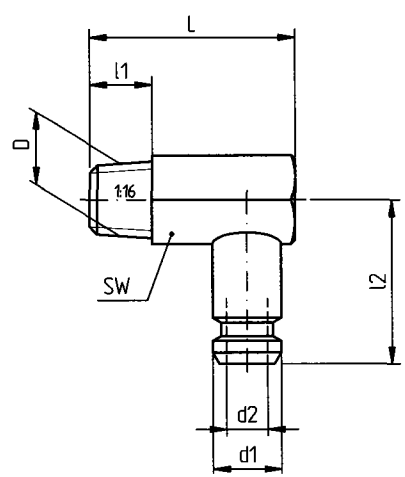

D	d1	d2	L	l1	l2	SW
M8×0.75	9	4.5	27	9	23	11
M10×1		6				
R1/8"						
M14×1.5	13	9	34		25	15
R1/4"						

Ms

Stand 05/94

## R512/DxL

D	d1	d2	SW	l1	L					
					120	150	240	300	360	450
9	10	6	11	21	□		□		□	
13	14	9	15	23		□		□		□

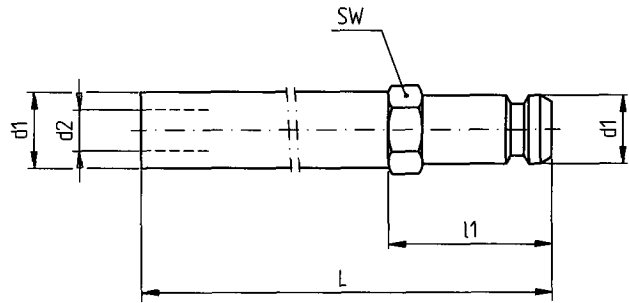

Ms

## R52/d1/D

D	d1	d2	L	l1	SW	bar	°C
M14x1.5	9	6	29	12	15	15	200/Viton
R1/4"							
M16x1.5	13	9	30		17	10	
R3/8"							

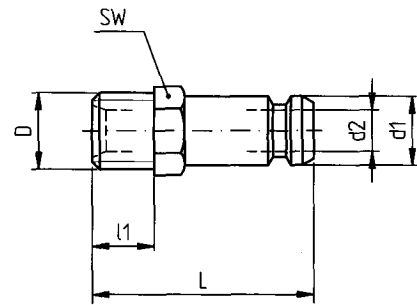

Ms

## R53/LxB

L	B	°C
12 m	13 mm	-160/+250

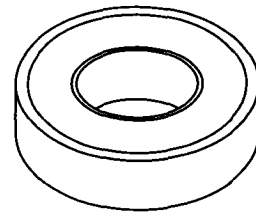

PTFE (Teflon)